

Bench Top

NEW IONIZER CLEANING BOX

EC-B_{SERIES}



Conforming to
EMC Directive



EC-B01-EX



EC-B02-EX

Direct ion / pulsed air emission



Direct ion emission paired with pulsed air emission provides quick and effective removal of static charges along with any dust that is present on the part.

White LED illumination



The white LED illuminates the work piece to ensure complete dust removal.

Dust collecting fan



A powerful dust collecting fan exhausts dust quickly, preventing re-adhesion of dust.

SPECIFICATIONS

Model No.	EC-B01-EX	EC-B02-EX
Charge removal time	0.5 sec. or less (Note 1)	
Ion balance	±10 V or less	
Applicable fluid	Air (dried clean air)	
Supplied air flow	Max. 300 l/min. (ANR) or less	Max. 500 l/min. (ANR) or less
Air pressure range	0.05 to 0.50 MPa	
Power supply voltage	Accessory AC adapter (Note 2) INPUT: 100 to 240 V AC ±10 % 50/60 Hz (OUTPUT: 24 V DC)	
Power consumption	80 VA or less	90 VA or less
Timer mode	2 sec. / 5 sec. / 10 sec. / synchronized with sensor or with external input selectable by switch	
Pulse air mode	Pulse 1 (long) / Pulse 2 (short) / OFF (continuous) selectable by switch	
Net weight	Main body: 6.5 kg approx	Main body: 13 kg approx

Notes: 1) Typical value at 100 mm 3.937 in from the front of air outlet at an applied air pressure of 0.50 MPa.

2) Please prepare an AC cable separately as it is needed. The following cables are available as optionals:
CN-ACCN-C2: AC cable (conforming to CCC), **CN-ACKR-C2**: AC cable (conforming to KTL)

OPTIONS

EC-BD50 / ø50 duct flange

A flange that connects a ø50 mm ø1.969 in duct hose for air exhaust to the EC-B main body

EC-BD76 / ø76 duct flange

A flange that connects a ø76 mm ø2.992 in duct hose for air exhaust to the EC-B main body

EC-BFX3 / Filter for EC-B01-EX

Replacement filter: 3 pcs. per set

EC-B2FX3 / Filter for EC-B02-EX

Replacement filter: 3 pcs. per set

EC-BAS / Spot nozzle

Exclusive nozzle for EC-B02-EX.
 Ionized air can be collected around the center. 2 pcs. per set.

DIMENSIONS (Unit: mm in)

The CAD data in the dimensions can be downloaded from the SUNX website: <http://www.sunx.com>

EC-B01-EX

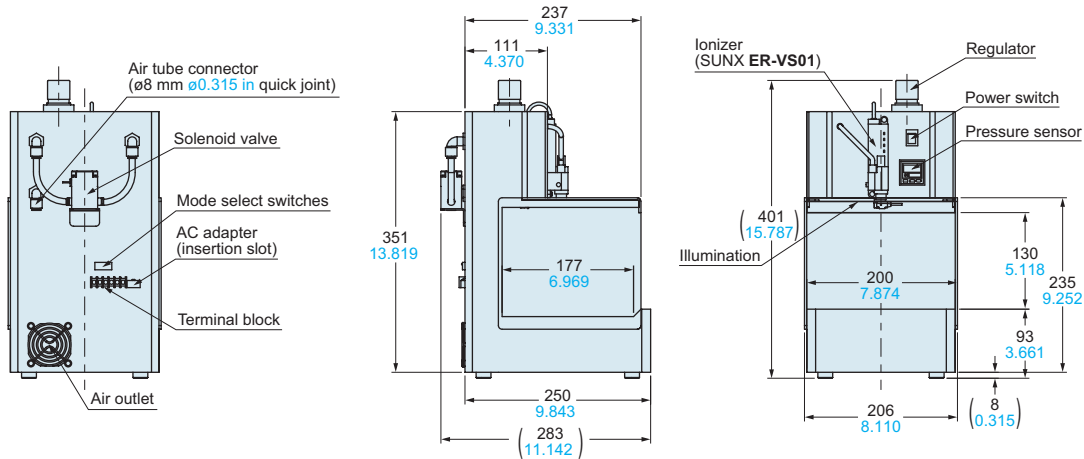

EC-B02-EX

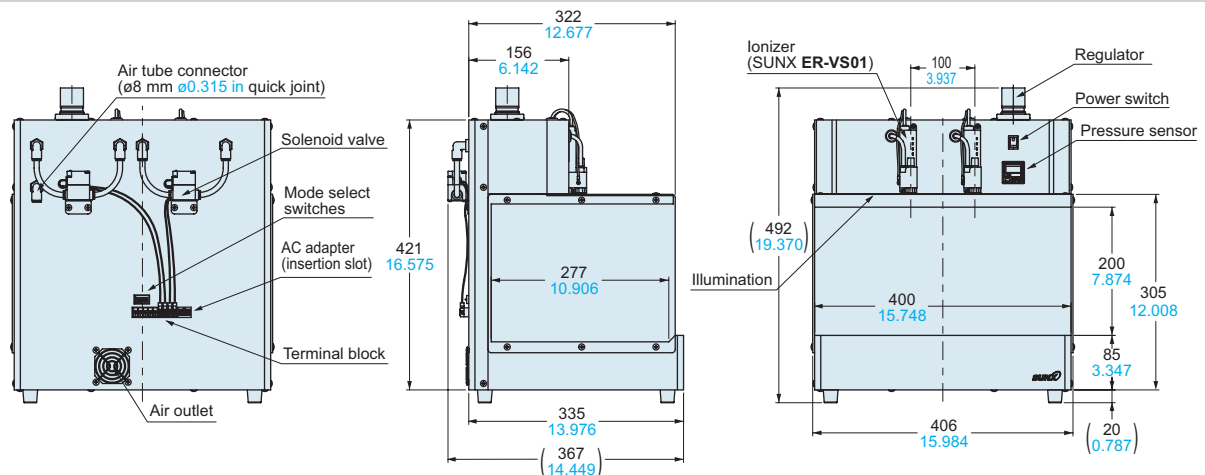

All information is subject to change without prior notice.



SUNX Limited

2431-1 Ushiyama-cho, Kasugai-shi, Aichi,
 486-0901, Japan
 Phone: +81-568-33-7211
 FAX: +81-568-33-2631

Overseas Sales Division

Phone: +81-568-33-7861
 FAX: +81-568-33-8591

<http://www.sunx.com>