



MS-Graessner GmbH & Co. KG

THE GEAR COMPANY

POWER GEAR^{HS}

The HighSpeed bevel gearbox



Nothing but highlights!

POWER GEAR^{HS}

Designed for special requirements – no adaption, no compromises: There are decades of engineering expertise of MS-Graessner in the newly developed PowerGear^{HS} series.

Thus each individual component was consistently developed and designed to meet the requirements at the highest speeds. With a multitude of benefits for a variety of applications and fields of application. In short, a bevel gearbox like no other.

- Gearbox for highest speeds
- for dynamic servo drive-train units
- higher permissible thermal performance limit
- low backlash and high transmission accuracy
- Motor mounting via coupling and lantern
- friction-locked shaft-and-bevel-gear-fit
- suitable as pre-stage for coaxial gearboxes
- energy-saving due to high efficiency rating of 98%

Optimized Gleason gearing for higher speeds

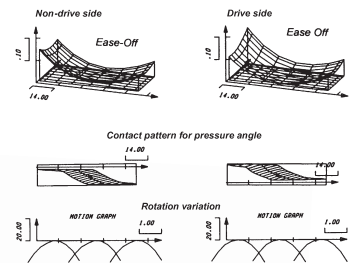

Non-wearing torque transmission through friction-locked shaft-and-bevel-gear-fit

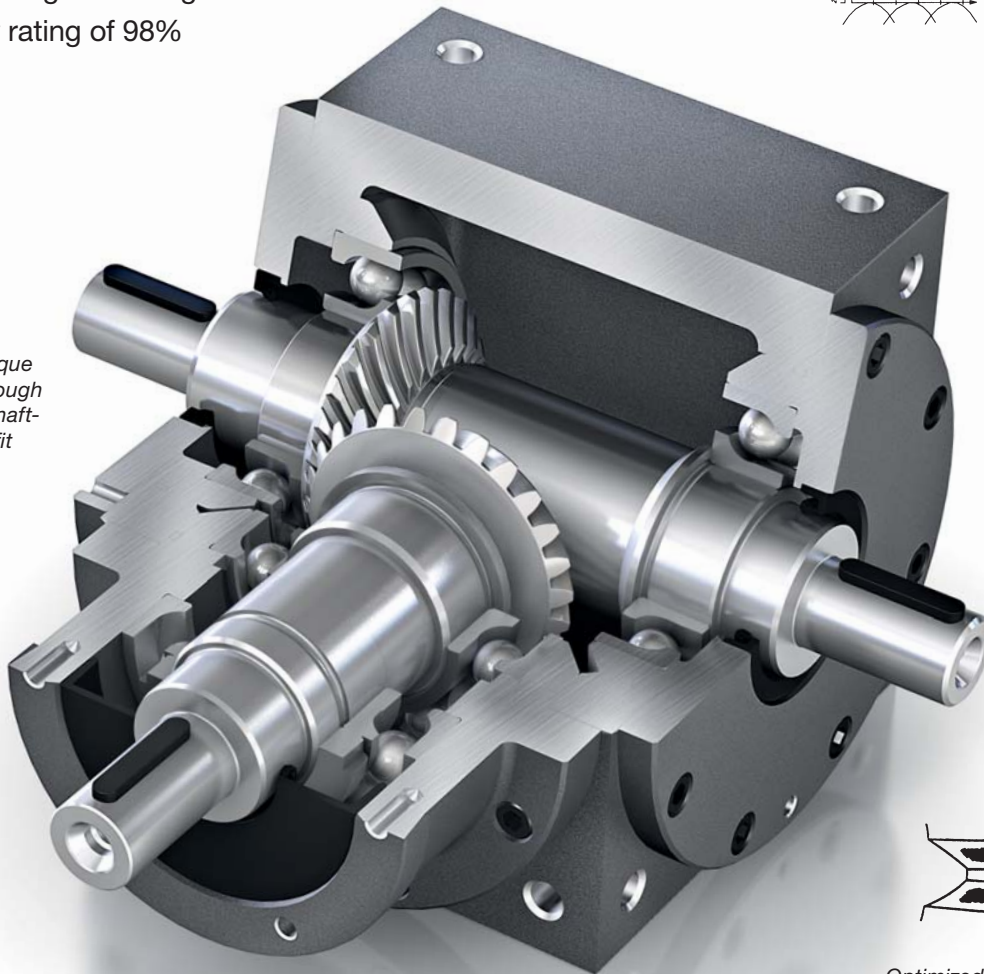

Optimized Gleason Gearing for highest speeds

Configurations	L, H, KL, KH
Shaft arrangement	WA 1, WA 3, WA 13, WA 12, WA 23, WA 123
Sizes	S75, S90, S110, S140, S170
Ratios	$i = 1.0 / 1.5 / 2.0$
Input speed	up to 8500 min^{-1}
Motor mounting	via coupling and lantern (KL/KH)

Options

- additional cooling: oil circulation system for cooling, cooling packs with or without additional fan
- extended output hollow shaft for shrink disc (with or without shrink disc)
- customized designs
- mounting feet
- also available in stainless steel

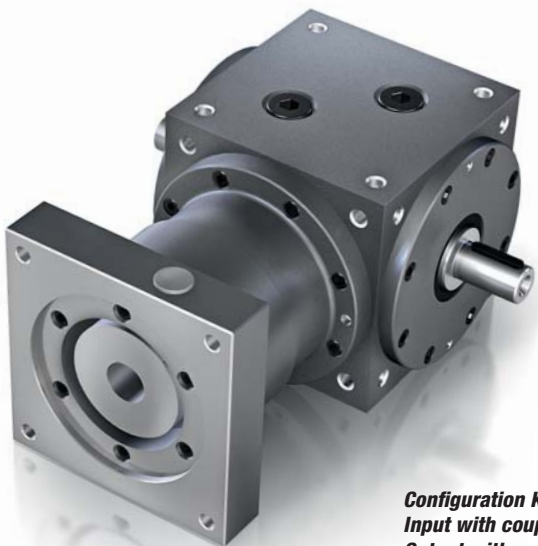

Configuration KL
Input with coupling and lantern.
Output with solid shaft on both sides or on one side.



Configuration L
Input and output with solid shaft.
Output on both sides or on one side.

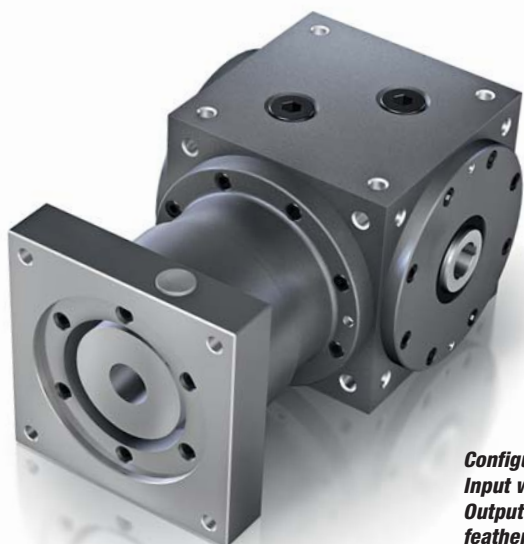

Configuration KH
Input with coupling and lantern.
Output with hollow shaft and feather key groove.



Configuration H
Input with solid shaft.
Output with hollow shaft and feather key groove.

Performance table HS-Version

POWER GEAR^{HS}

	Abbr	Unit	S75	S90	S110	S140	S170	
Output torque ①								
Nominal torque	i=1.0:1	T _{2N}	Nm	25	45	78	150	360
Maximum acceleration ②		T _{2B}	Nm	38	68	117	225	540
EMERGENCY STOP torque ③		T _{2Not}	Nm	50	90	156	300	720
Nominal torque	i=1.5:1	T _{2N}	Nm	25	45	78	150	360
Maximum acceleration ②		T _{2B}	Nm	38	68	117	225	540
EMERGENCY STOP torque ③		T _{2Not}	Nm	50	90	156	300	720
Nominal torque	i=2.0:1	T _{2N}	Nm	24	42	68	150	330
Maximum acceleration ②		T _{2B}	Nm	36	63	102	225	495
EMERGENCY STOP torque ③		T _{2Not}	Nm	48	84	136	300	660
Input speed	i=1.0:1	n _{1nenn}	min ⁻¹	3300	3000	2800	2500	2000
Applies at 50% of nominal torque at 20° C ambient temperature	i=1.5:1; 2.0:1	n _{1nenn}	min ⁻¹	4000	3500	3200	3000	2600
	i=1.0:1 - 2.0:1	n _{1max} ④	min ⁻¹	8500	8500	7000	5500	4000
Output backlash ⑤	nominal	j _t	arcmin	≤16	≤15	≤14	≤13	≤12
	reduced	j _t	arcmin	≤10	≤9	≤8	≤8	≤7
Permissible radial load ⑥		F _{1Rmax}	N	650	900	1300	2000	3500
		F _{2Rmax}	N	800	1100	1600	2500	4500
Permissible axial load ⑥		F _{1Amax}	N	325	450	650	1000	1750
		F _{2Amax}	N	400	550	800	1250	2250
Efficiency at max load		η	%	>98	>98	>98	>98	>98
Running noise at 1500 min⁻¹, partial load		L _{pA}	db(A)	≤70	≤70	≤74	≤76	≤77
Weight approx.		m	kg	3.9	4.5	8.0	13.0	22.0
Service life		L _n	h	>15000	>15000	>15000	>15000	>15000
Lubrication	Synthetic oil ISO VG 150							
Average oil quantity			l	0.1	0.2	0.3	0.4	1.0
Operating temperature	°C							
	-30 to 100							
Paint	Primer RAL 9005 - dull black							
Mass moments of inertia ⑦ related to input	i=1.0:1	I ₁	kgcm ²	0.73	1.33	3.88	9.26	31.6
	i=1.5:1	I ₁	kgcm ²	0.49	0.95	2.88	6.31	19.6
for shaft arrangement WA 13	i=2.0:1	I ₁	kgcm ²	0.38	0.77	2.38	4.60	13.8

Ex-protection: Ex II 2 D/G c T4

Type of protection: IP 64

① Design K: permissible torque depends on selected coupling

② Max. 1000 cycles per hour, otherwise please contact us

③ Max. 1000 times during the service life of the gearbox

④ Observe permissible operating temperatures

⑤ Assuming 2% load and max. 10 Nm at the output

⑥ Point of force application center of shaft at an output speed of n = 400 min⁻¹

⑦ Design K: without mass moments of inertia of coupling

**As a function of the thermal power limit, higher speeds at a reduced torque are possible.
For an optimal design of your application, please contact us.**

Please note that

All information contained in this catalogue is provided without guarantee and is not binding. In particular, dimensions and values only provide guidance. Any exact, specific requirements must be agreed with us. Specifications and features listed in the catalogue are subject to a written contract.

Dimensions and shaft arrangements HS-Version configuration L

POWER GEAR^{HS}

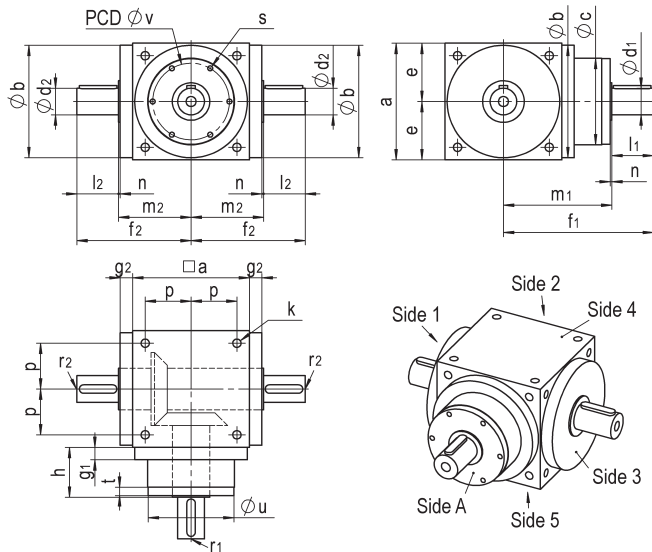

always right view = mirrored illustration

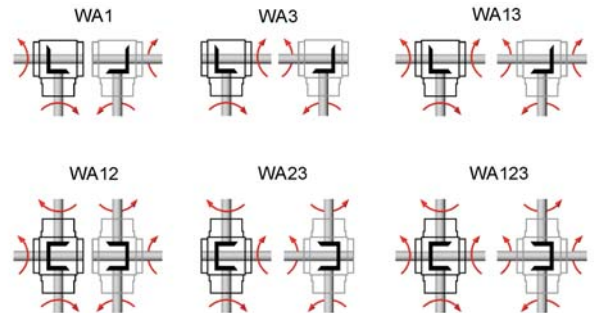

	S75L	S90L	S110L	S140L	S170L
a	75	90	110	140	170
Øb _{h7}	73	88	108	135	165
Øc	72	86	106	104	128
Ød _{1 k6}	12	16	18	22	32
l ₁	26	30	35	40	50
Ød _{2 k6}	12	16	18	22	32
l ₂	26	30	35	40	50
e	37,5	45	55	70	85
f ₁	116	130	150	170	205
f ₂	75,5	87	102	122	149
g ₁	15	15	15	15	15
g ₂	10	10	10	10	12
h	52,5	55	60	60	70
k	M6x12	M6x12	M8x15,5	M10x19,5	M12x23
m ₁	90	100	115	130	155
m ₂	49,5	57	67	82	99
n ₁	2	2	2	2	2
n ₂	2	2	2	2	2
p	30	36	44	55	67
r ₁ *	M4	M5	M6	M8	M12
r ₂ *	M4	M5	M6	M8	M12
s	4xM5x9	4xM5x12	6xM6x12	6xM6x12	6xM8x16
t	8	8	8	10	10
Øu _{g6}	72,9	87	107	107	127
Øv	62	76	92	92	114
Feather key _{d1} **	4x4x20	5x5x25	6x6x28	6x6x32	10x8x45
Feather key _{d2} **	4x4x20	5x5x25	6x6x28	6x6x32	10x8x45

* According to Form D, DIN332

** Feather key to DIN6885/1

Dimensions and shaft arrangements HS-Version configuration H

POWER GEAR^{HS}

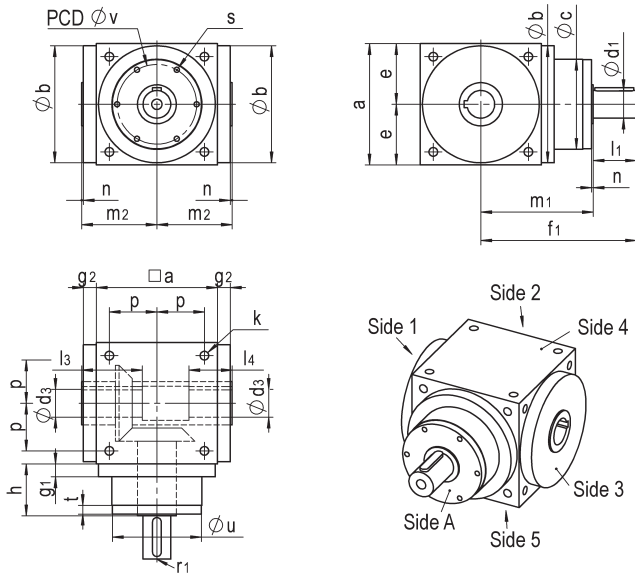

right view = mirrored illustration

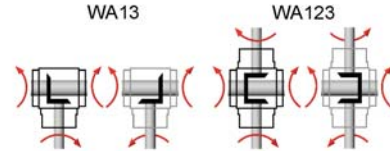

	S75H	S90H	S110H	S140H	S170H
a	75	90	110	140	170
Øb _{h7}	73	88	108	135	165
Øc	72	86	106	104	128
Ød _{1 k6}	12	16	18	22	32
l ₁	26	30	35	40	50
Ød _{3 H7}	12	14	18	22	32
l ₃	42	49	61	70	85
l ₄	30	30	35	35	50
e	37.5	45	55	70	85
f ₁	116	130	150	170	205
g ₁	15	15	15	15	15
g ₂	10	10	10	10	12
h	52.5	55	60	60	70
k	M6x12	M6x12	M8x15.5	M10x19.5	M12x23
m ₁	90	100	115	130	155
m ₂	49.5	57	67	82	99
n ₁	2	2	2	2	2
n ₂	2	2	2	2	2
p	30	36	44	55	67
r ₁ *	M4	M5	M6	M8	M12
s	4xM5x9	4xM5x12	6xM6x12	6xM6x12	6xM8x16
t	8	8	8	10	10
Øu _{g6}	72.9	87	107	107	127
Øv	62	76	92	92	114
Feather key _{d1} **	4x4x20	5x5x25	6x6x28	6x6x32	10x8x45
Feather key groove _{d2} **	4x4	5x5	6x6	6x6	10x8

* According to Form D, DIN332

** Feather key/Feather key groove to DIN6885/1

Dimensions Input

HS-Version configuration KL/KH

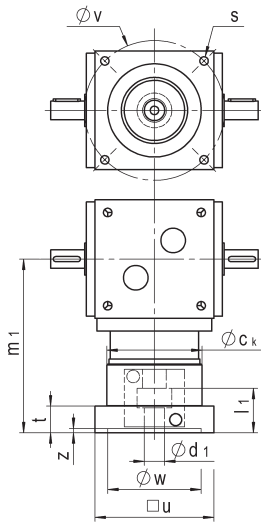

Design KL

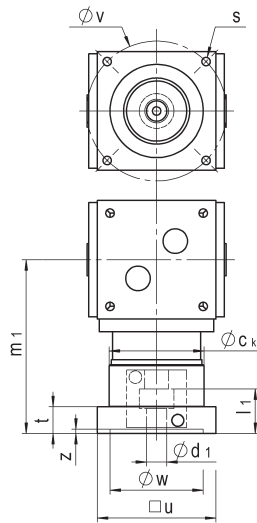

Design KH

Size	Variant	Ød ₁	l ₁	□u	Øv	Øw ^{F7}	s	m ₁	t	z	Øc _k
S75	V1	9	20	75	63	40	M4	146.5	25	5	77
	V2	11	23	75	75	60	M5	146.5	25	5	77
	V3	14	30	90	100	80	M6	146.5	25	5	77
S90	V1	11	26	90	75	60	M5	166.5	25	5	92
	V2	14	30	90	75	60	M5	166.5	25	5	92
	V3	14	30	90	95	70	M6	166.5	25	5	92
	V4	14	30	90	100	80	M6	166.5	25	5	92
	V5	19	40	90	95	70	M6	166.5	25	5	92
	V6	19	40	90	100	80	M6	166.5	25	5	92
	V7	19	40	115	130	95	M8	166.5	25	5	92
	V8	19	40	115	115	95	M8	166.5	25	5	92
	V9	24	50	115	130	110	M8	173	31.5	5	92
S110	V1	14	30	110	95	80	M6	184.5	26	5	112
	V2	14	30	110	100	80	M6	184.5	26	5	112
	V3	19	40	110	100	80	M6	184.5	26	5	112
	V4	19	40	115	115	95	M8	188	29.5	5	112
	V5	19	40	115	130	95	M8	188	29.5	5	112
	V6	19	40	115	130	110	M8	190	31.5	5	112
	V7	24	50	115	130	110	M8	190	31.5	5	112
	V8	24	50	140	165	110	M10	190	31.5	5	112
	V9	24	50	140	165	130	M10	205	21.5	5	112
	V10	32	60	140	165	130	M10	205	21.5	5	112
S140	V1	19	40	115	115	95	M8	203	29.5	5	112
	V2	19	40	115	130	95	M8	203	29.5	5	112
	V3	24	50	115	130	110	M8	205	31.5	5	112
	V4	24	50	140	165	110	M10	205	31.5	5	112
	V5	24	50	140	165	130	M10	220	21.5	5	112
	V6	32	60	140	165	130	M10	220	21.5	5	112
	V7	32	60	190	215	130	M12	221	22.5	6	112
	V8	32	60	190	215	180	M12	235	36.5	6	112
	V9	38	80	190	215	180	M12	235	36.5	6	112
S170	V1	24	50	140	165	110	M10	241	28.5	5	135
	V2	24	50	140	165	130	M10	244	31.5	5	135
	V3	32	60	140	165	130	M10	244	31.5	5	135
	V4	32	60	190	215	130	M12	262.5	26.5	6	135
	V5	32	60	190	215	180	M12	264	28	6	135
	V6	38	80	190	215	180	M12	264	28	6	135

BEVEL GEAR



Spiral, Hypoid and Zerol Bevel Gears

- Standard range of products and custom-made versions
- Module ms from 0.5 to 12
- Diameters up to 410 mm
- Shaft angles from 10° to 170°
- More than 60 years of experience
- In-house gearing calculations
- We manufacture to your drawing or advise you of possible alternatives
- Milled or ground gear tooth cutting

POWER GEAR



The high performance bevel gearbox

- High torque, small size
- For highest input speeds
- Ratios from $i = 1:1$ to $5:1$
- Torques up to 7000 Nm
- Output via solid and hollow shaft
- Motor mounting either directly or via coupling and lantern
- Variable ratios and uniform dimensions

DYNA GEAR



The highly dynamic servo right angle gearbox

- Hypoid gearing
- High input speeds at medium to high torques
- Ratios single-stage $i = 3:1$ to $30:1$
- Ratios, two-stage, up to $150:1$
- Torques up to 1440 Nm
- Flexible motor mounting via coupling and lantern
- Low backlash < 2 arcmin
- Variable ratios and uniform dimensions

DYNA GEAR ^{Economy}

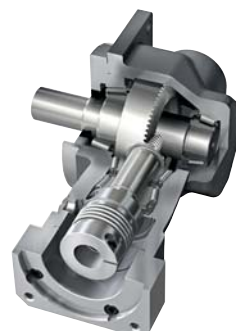

The cost-effective servo right angle gearbox

- Hypoid gearing
- High input speeds at medium torques
- Ratios single-stage $i = 5:1, 8:1, 10:1$ and $15:1$
- Torques up to 260 Nm
- Flexible motor mounting via coupling and flange
- Backlash < 6 arcmin
- Variable ratios and uniform dimensions

DESIGN GEAR



The customised gearbox

- Single-stage gearbox available as gear-change or reversing gearbox
- Forced oil circulation lubrication system gearbox for high speeds and torques
- Labyrinth sealed gearbox with an efficiency of $> 99\%$
- Special gearbox with additional functional elements
- Endless possibilities on request

KS TWIN GEAR

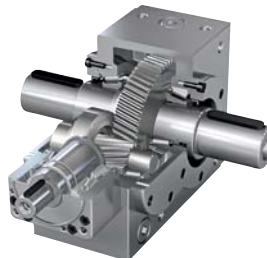

The bevel helical gearbox

- Two-stage bevel helical gearbox with ratios of up to $75:1$
- Torques up to 7500 Nm
- Torsional backlash < 6 arcmin
- Compact design
- Motor mounting either directly or via coupling and lantern
- High torsional stiffness
- High input speeds at high torques
- Variable ratios and uniform dimensions