

Operating manual: AdServo (Type VC and SLC)

This operating manual is intended to help you to commission the ATEK drive in accordance with relevant regulations. The stated features of our transmissions and the fulfilment of potential guarantee claims depend on compliance with these directions.

Before the drive was shipped, it was subject to strict tests and was properly packed. Before starting operation, check for transport damage. Report any damage to the transport company immediately.

If the transmission is not to be installed immediately, we request that you store it appropriately to its design in a dry place without mayor temperature changes.

Lubrication

Please refer to the information given on the identification plate on the transmission! Transmissions with lifetime lubrication have been factory fitted with the necessary amounts of lubricants. Subsequent lubrication is only necessary when a substantial amount of lubricant has escaped due to leakage. The type and viscosity of lubricant to be added must be obtained from the manufacturer whilst stating the serial number of the transmission.

Transmissions for oil change lubrication are delivered without lubricant and must be filled before commissioning with an oil or grease in accordance with our lubricant recommendation.

Assembly

The transmissions should always be installed according to the fitting position that has been ordered.

The gear unit should be set up on appropriate solid foundations or mounted as a flange drive directly on the machine to be driven. The shaft ends have to be aligned very carefully for quiet running and safety during operation. To compensate for minor mounting inaccuracies we recommend the use of elastic couplings. The couplings must be warm or must be mounted with the aid of D-centring and a screw. Do not hammer! This will avoid damage to the tooth profile, rolling bearings and locking rings.

Plug-in transmissions can be fitted directly onto the shaft of the driven machine. For flange gears it is important that the attachment surface is at exact right angles to the machine shaft's axis. Otherwise the bearings will suffer too much stress and might be damaged. The reaction torque corresponding to the output torque can be supported with a torque converter bearing. The bar should be mounted on the gears' machine side in order to prevent additional bending stresses. Do not mount the gears directly on a foundation plate when the machine shaft is bedded near the gears.

For hollow shafts with a shrunk-on flange, please additionally refer to our assembly instructions for shaft-hub-connections.

Commissioning

Where ventilation of the transmission is desired, the vent hole is sealed for transport. To prevent excess pressure in the transmission and hence leakage the locking screw must be removed and replaced by the provided venting filter before setting the gear in motion. If the temperature of the gear box housing does not exceed 50°C during operation, the vent filter must not be fitted.

Maintenance

All ATEK drives require only a minimum of maintenance. For drives with lifetime lubrication this is reduced to regular checks of the transmission for lubricant loss through leakage.

Motor Mounting Information

Warning: You may only assemble, operate and maintain the coupling if you have carefully read through the mounting instructions on the back of this page and understood them and if you are authorized and have proper skills!

The axial, play-free plug-in shaft coupling with integrated frictionally engaged shaft-to-hub connections permits a simple blind assembly and consists of 3 parts:

1. Conical hub, already mounted on the drive shaft of the transmission.
2. Plastic involute annular gear
3. Clamping hub type KN or KNN or clamping ring hub (2 parts) type SN

The power is transmitted by frictional engagement between the functional surfaces. With type KNN an additional interlocking is achieved with the use of a parallel key. Particular attention must be paid to the controlled tightening of the locking screws or draw spindles and to the condition of the contact surfaces. Tolerance for fitting of motor shaft - hub k6/H7. The torques indicated in the catalogue may change with other shaft tolerances – please contact ATEK – Technique for further information.

Assembly of clamping hub on to the motor shaft

Clean and degrease the hub bore and the shaft.

Release the clamping screw slightly, push the hub onto the shaft, measure dimension A at the gear unit - adjust dimension B (from table 3). Tighten the clamping screw with the tightening torque indicated in table 1.

Table 1

Size of coupling	14	19/24	24/28	28/38	38/45
Diameter D [mm]	30	40	55	65	80
Clamping screw DIN 912	M3	M6	M6	M8	M8
Pulling torque TA [Nm]	1,34	10,5	10,5	25	25

Assembly of clamping ring hub on to the motor shaft

Clean the hub bore and the shaft and oil them afterwards with liquid oil (e.g. with Castrol 4 in 1).

Caution: Do not use oil and grease with molybdenum disulphide or other high pressure additions as well as sliding grease pastes.

Release the clamping screws slightly and pull of the clamping ring slightly from the hub, so that the clamping ring is released. Push the clamping ring hub on to the motor shaft - measure dimension A at the gear unit - adjust dimension B (from table 3). Tighten the clamping screws crosswise and evenly until the tightening torque indicated in table 2 is reached. Repeat this until all clamping screws reach this tightening torque.

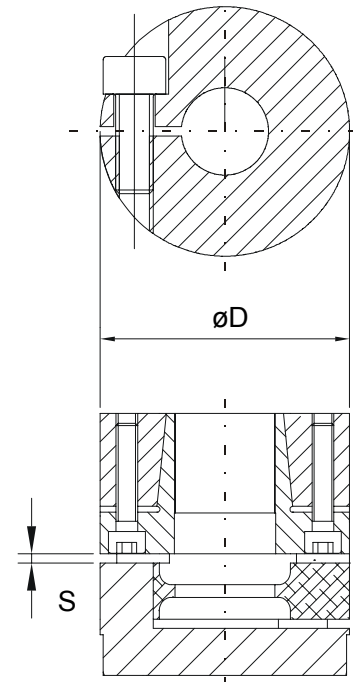

Table 2

Size of coupling	14	19/24	24/28	28/38	38/45
Diameter D [mm]	30	40	55	65	80
Clamping screws	4xM3	6xM4	4xM5	8xM5	8xM6
Pulling torque TA [Nm]	1,34	2,9	6	6	10

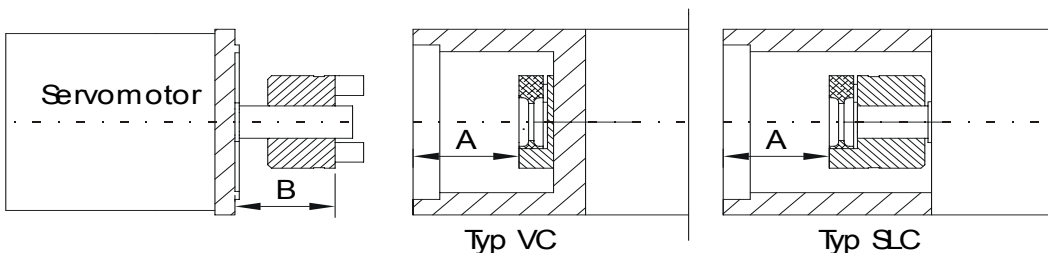

Table 3

Size of coupling	14	19/24	24/28	28/38	38/45
Diameter D [mm]	30	40	55	65	80
Distance dimension S	1,5	2	2	2,5	3
Dist. dimension B = (A - S)	A - 1,5	A - 2	A - 2	A - 2,5	A - 3

Regal A/S

Industrivej 4 · 4000 Roskilde · Tlf: 4677 7000 · Fax: 4675 7620 · regal@regal.dk · www.regal.dk