

Operating instructions: Type VLM and SLM

This operating manual is intended to help you to commission the ATEK drive in accordance with relevant regulations. The stated features of our transmissions and the fulfilment of potential guarantee claims depend on compliance with these directions.

Before the drive was shipped, it was subject to strict tests and was properly packed. Before starting operation, check for transport damage. Report any damage to the transport company immediately.

If the transmission is not to be installed immediately, we request that you store it appropriately to its design in a dry place without mayor temperature changes.

Lubrication

Please refer to the information given on the identification plate on the transmission!

Transmissions with lifetime lubrication have been factory fitted with the necessary amounts of lubricants. Subsequent lubrication is only necessary when a substantial amount of lubricant has escaped due to leakage. The type and viscosity of lubricant to be added must be obtained from the manufacturer whilst stating the serial number of the transmission.

Transmissions for oil change lubrication are delivered without lubricant and must be filled before commissioning with an oil or grease in accordance with our lubricant recommendation.

Assembly

The transmissions should always be installed according to the fitting position that has been ordered.

The gear unit should be set up on appropriate solid foundations or mounted as a flange drive directly on the machine to be driven. The shaft ends have to be aligned very carefully for quiet running and safety during operation. To compensate for minor mounting inaccuracies we recommend the use of elastic couplings. The couplings must be warm or must be mounted with the aid of D-centring and a screw. Do not hammer! This will avoid damage to the tooth profile, rolling bearings and locking rings.

Plug-in transmissions can be fitted directly onto the shaft of the driven machine. For flange gears it is important that the attachment surface is it exact right angles to the machine shaft's axis. Otherwise the bearings will suffer too much stress and might be damaged. The reaction torque corresponding to the output torque can be supported with a torque converter bearing. The bar should be mounted on the gears' machine side in order to prevent additional bending stresses. Do not mount the gears directly on a foundation plate when the machine shaft is bedded near the gears.

For hollow shafts with a shrunk-on flange, please additionally refer to our assembly instructions for shaft-hub-connections.

Commissioning

Where ventilation of the transmission is desired, the vent hole is sealed for transport. To prevent excess pressure in the transmission an hence leakage the locking screw must be removed and replaced by the provided venting filter before setting the gear in motion. If the temperature of the gear box housing does not exceed 50°C during operation, the vent filter must not be fitted.

Assembly

The installation in hazardous locations is not permitted, except with motors that have the appropriate approval. The supplied type of protection and thermal class are to be compared with the conditions in the place of installation. A stoppage heating is recommended for locations that have a large variation in temperature or high air humidity. Attention has to be paid to sufficient admission of fresh air and unobstructed cooling fins as well as open air intakes an outlet on the ventilator. The distance between the air inlet opening and the nearest wall should be equivalent to at least half the diameter of the motor. For vertical mounting with the ventilator mounted above the motor, we recommend ventilator cover or a cover integrated into the equipment. The foundation work must be executed evenly, cleanly and durably and has to be dimensioned to withstand the occurring moments of torques. Misalignment in the drive system, as well as shock and unbalanced parts must be avoided.

Checks before commissioning

Before commissioning the insulation resistance of the engine coils must be checked. It should be higher than 5M Ω at 25°C. If this value is not achieved, a specialist must be consulted.

Electrical connections

The motor may only be connected by competent personnel. The electrical connection must correspond with the valid safety regulations. The power and current data must correspond with the data of electrical mains supply. Voltage and frequency fluctuations are subject to DIN EN 60034-1. 50Hz motors can be connected to a 60Hz mains supply if the change in the power, voltage, torque and number of rpm are considered. All cross-section of all connecting cables must be adequately dimensioned (DIN VDE 0298). The grounding connection is located in the proximity of, or directly in the terminal box. Cable entries are to be provided with screwed connections according to DIN 46320/T1.

Direction of rotation

Transmissions with standard motors can be connected in both directions of rotation. When viewing the end of the transmission shaft, the direction of rotation "right" means that the shaft is turning in the clockwise direction. For checking the direction of rotation, the drive should be operated first in its installation position without any machine parts connected (refer to the fitting instructions). We recommend first connecting the phase sequence L1, L2, L3 to the clamps U1, V1 and W1. A change to the direction of rotation can subsequently be made swapping any two cables.

Motor-protection mechanisms

To protect the drive unit against a short-circuit; overload or single-phase operation, sufficiently dimensioned protective switches or fuses with thermal over current relays should be fitted. Installed PTC feelers (thermistors) are to be connected to a suitable actuating device. Thermostats are prewired for automatic switching.

Starting squirrel cage motors

If direct engagement is selected as the starting procedure for the drive, the electrical mains supply connected and the supply lines must be able to carry the starting current. If the connected machine does not need an increased starting torque (the resistive torque of the machine is smaller than the rated load torque of the drive), the star-delta starting is to be preferred. This avoids the strong initial jolt and with frequent starting procedures, the life span of the drive is increased. The starting current and the starting torque are approx. 30% lower than during direct engagement.

The switching of the star into the delta connection should be made at approximately the nominal motor speed. Otherwise, the switching current is almost as large as during direct engagement. The motor can also be started through the use of starting transformers, intermediate resistors or stator resistors. These are connected to the terminals of the terminal box and cause the reduction of torque in proportion to the square of the voltage and of the reduction of the nominal current linear with the voltage.

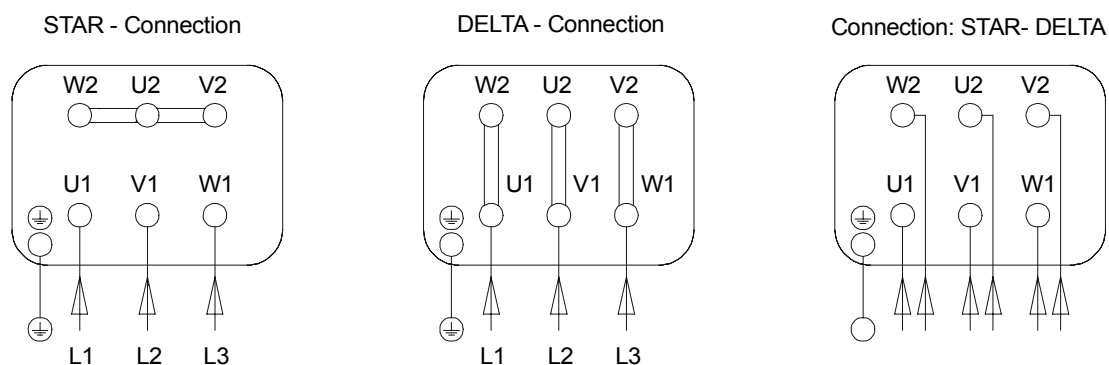

Maintenance

All ATEK drives require only a minimum of maintenance. For drives with lifetime lubrication this is reduced to regular checks of the transmission for lubricant loss through leakage.

Regal A/S

Industrivej 4 · 4000 Roskilde · Tlf: 4677 7000 · Fax: 4675 7620 · regal@regal.dk · www.regal.dk