

Aufsteck- und Flachgetriebemotoren

Leistung: 0,12 – 55 kW
Drehmoment: 27 – 14.000 Nm
Übersetzung: 0,8 – 18.600

Shaft mounted and Parallel shaft geared motors

Power: 0.12 – 55 kW
Torque: 27 – 14,000 Nm
Ratio: 0.8 – 18,600

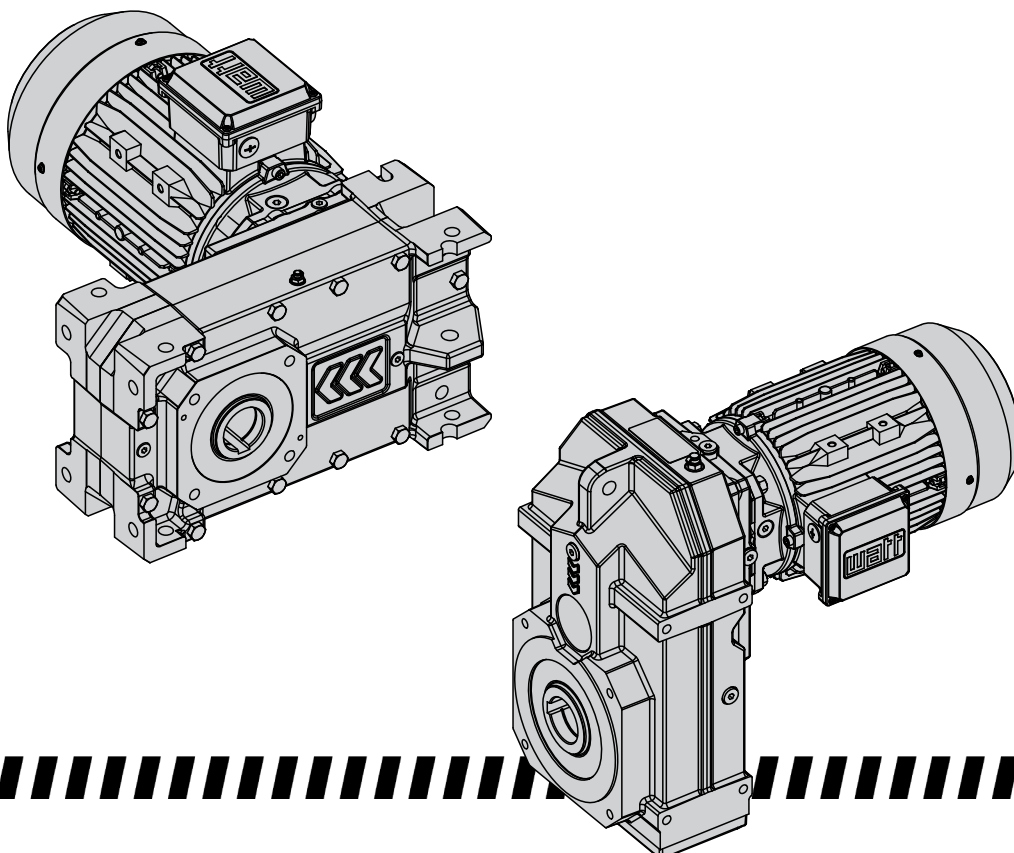

AF
UNBLOCK®

Die Aufsteckgetriebemotoren stellen speziell in der Fördertechnik eine besonders wirtschaftliche Antriebslösung dar. Die Getriebe werden direkt auf die Kundenwelle aufgesteckt, die Supportnase dient in Kombination mit dem Gummipufferset als Drehmomentstütze. Als axiale Befestigung des Getriebes auf der Arbeitsmaschine wird das Befestigungsset verwendet. Entsprechend dem UNIBLOCK® DESIGN können die Gehäuse auch mittels der seitlichen Befestigungsflächen montiert werden.

Hohe Untersetzungsbereiche in den 2-stufigen Basisausführungen decken große Drehzahlbereiche bei gleichzeitig kompakter Gehäuseform ab.

Die Flachgetriebemotoren ermöglichen durch das UNIBLOCK® DESIGN eine Vielzahl von Einbaumöglichkeiten. Durch die allseitig bearbeiteten Getriebegehäuse und die besonders formstabile Gehäuseausführung können diese Antriebe sowohl für Fuß- und auch Flanschmontage eingesetzt werden.

Ab Baugröße F. 111. (5.000Nm) sind die Getriebe mit Drehmomentstütze ausgeführt (SUPPORT DESIGN), wodurch die Auswahl von Aufsteckgetriebemotoren vervollständigt wird. Der Kunde hat zusätzlich durch Verwendung von verschiedenen Anbauteilen aus dem MAS® Programm die Möglichkeit die Montagevariante noch weiter zu steigern.

Shaft mounted geared motors offer an extremely economical drive solution that is particularly suitable for materials-handling technology. The drive is mounted directly onto the customer's shaft, the support nose together with the set of rubber buffers serving as a torque arm. A shaft mounting kit provides the axial attachment of the drive to the machine. According to the UNIBLOCK® DESIGN the housing can also be fastened using the lateral attachment surfaces.

The high gear reductions of the two-stage basic models enable them to cover a wide range of speeds with a compact housing.

The UNIBLOCK® DESIGN of our parallel-shaft geared motors enables them to be installed in a multitude of ways. The gear casings are particularly sturdy and are machined on all sides, enabling these drive systems to be either foot mounted or flange mounted.

From size F. 111. (5.000 Nm) the gear systems are equipped with torque arms (SUPPORT DESIGN), completing the range of shaft mounted geared motors. Customers can also use a variety of additional components from the MAS® programme to further extend their assembly options.

4

UNIBLOCK® Integrierte Flanschausführung mit seitliche Befestigungsflächen
Integrated flange with lateral mounting surfaces

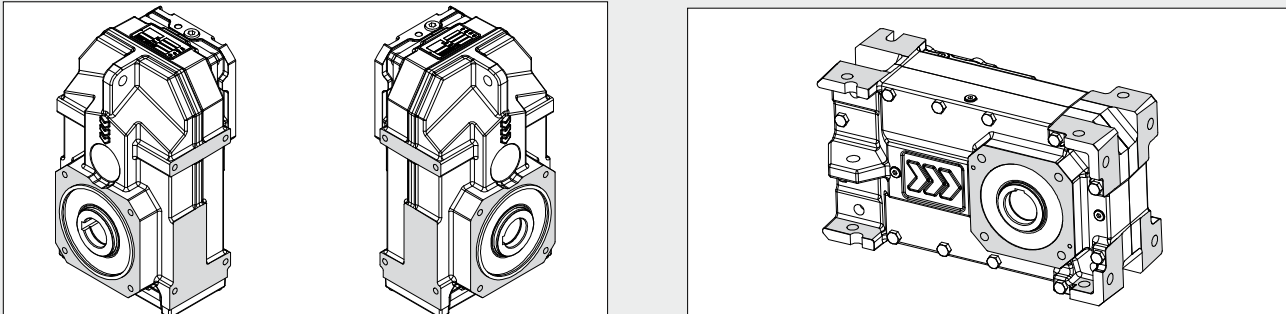

SUPPORT Support-Nase für Drehmomentabstützung
Support nose for fixing the torque reaction

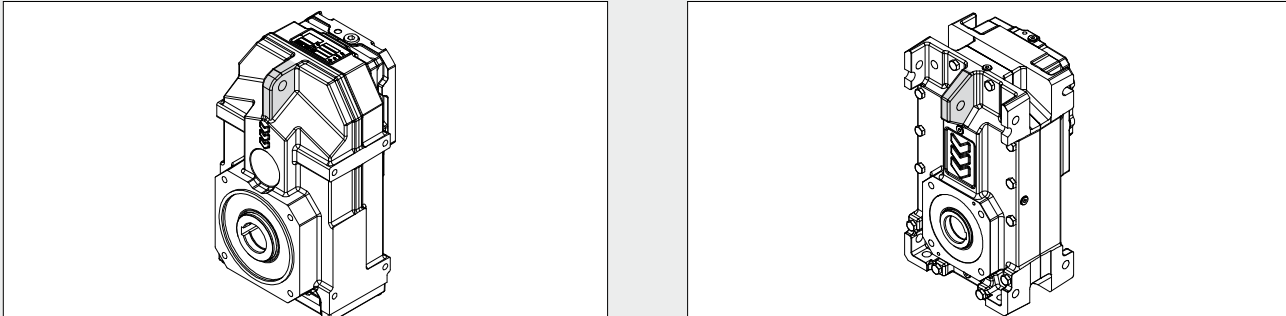

FLANSCH / FLANGE

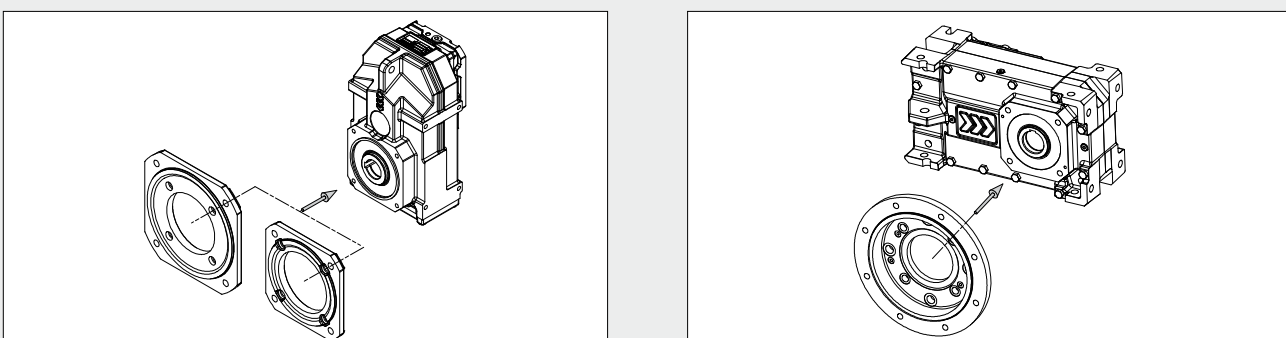

Die Bestelltypenbezeichnung besteht aus einer Kombination von Zahlen und Buchstaben.
 Eine detaillierte Beschreibung der einzelnen Schlüssel finden Sie auf folgenden Seiten (Seitenverweise siehe unten).

The order type designation consists of a combination of figures and letters.
 A detailed description of the separate keys can be found on the following pages (page references see below).

Bestellbeispiele:

ASA 66A 70 101L4
 AFS 56C IA 70 91L4-SH-FL-SD
 FSA 111A 70 161M4-BR150
 FSA 131C WN

Ordering examples:

ASA 66A 70 101L4
 AFS 56C IA 70 91L4-SH-FL-SD
 FSA 111A 70 161M4-BR150
 FSA 131C WN

G					M
1	2	3	4	5	...
A	S	A	66	A	70 101L4
A	F	A	46	A	70 101L4
F	S	S	56	S	IAK 70 101L4
	U	Z	66	C	IAK100
			76	D	SA142
			86	F	NA56
			111		WN
			131		IEC200
			137		

siehe Seite / see page 574

siehe Seite / see page 181

Seite	Bezeichnung	Kennz. Note	Designation	Page
178	Getriebebaureihe	G1	Gear unit model range	178
178	Getriebeausführung	G2	Gear unit design	178
178	Wellenausführung	G3	Shaft execution	178
179	Getriebegröße	G4	Size of the gear unit	179
180	Zahnradstufencode	G5	Gear stages code	180
181	Eintriebsart	M	Input type	181

Motortypenschlüssel siehe Seite 574.

Motor type designation see page 574.

Bezeichnung	Kennz. Note	Designation
Getriebebaureihe	G1	Gear unit model range

Aufsteckgetriebe	A	Shaft mounted gear unit
Flachgetriebe	F	Parallel shaft gear unit

A.. 46. - 86.

F. 111. - 137.

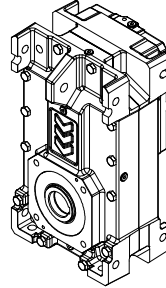
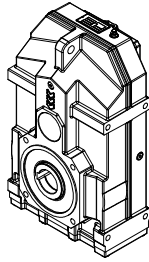

4

Bezeichnung	Kennz. Note	Designation
Getriebeausführung	G2	Gear unit design
Wellenausführung	G3	Shaft execution

SUPPORT - Ausführung	S	SUPPORT - type
UNIBLOCK® - Ausführung	U	UNIBLOCK® - type
Anbaufansch	F	Bolt - on flange
mit Abtriebswelle	-	with output shaft
mit Hohlwelle	A	with hollow shaft
mit Schrumpfscheibe	S	with shrink disc
mit beidseitiger Abtriebswelle	Z	with output shaft on both sides

AUFSTECKGETRIEBEMOTOR A.. 46. - 86.

SHAFT MOUNTED GEARED MOTOR A.. 46. - 86.

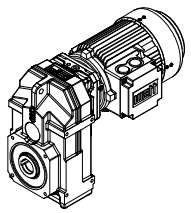
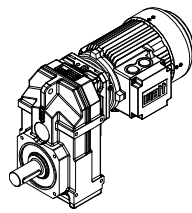
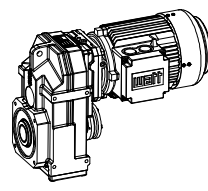
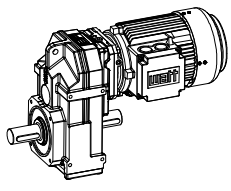
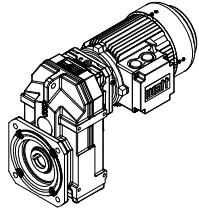
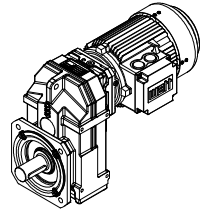
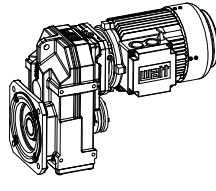
SUPPORT					
	ASA AUFSTECK SHAFT MOUNTED	AS ABTRIEBSWELLE OUTPUT SHAFT	ASS SCHRUMPFSCHEIBE SHRINK DISC	ASZ ABTRIEBSWELLE BEIDSEITIG OUTPUT SHAFT ON BOTH SIDES	
	FLANSCH / FLANGE				
		AFA AUFSTECK SHAFT MOUNTED	AF ABTRIEBSWELLE OUTPUT SHAFT	AFS SCHRUMPFSCHEIBE SHRINK DISC	

FLACHGETRIEBEMOTOR F. 111. - 137.

PARALLEL SHAFT GEARED MOTOR F. 111. - 137.

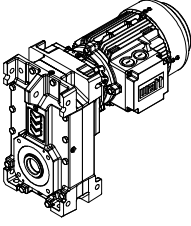
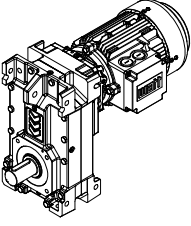
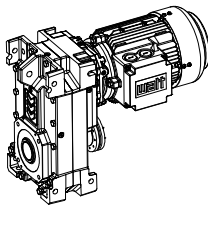
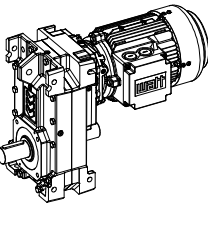
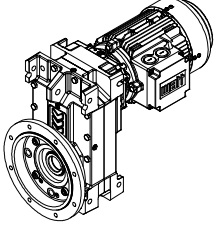
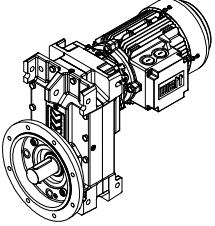
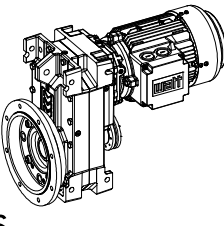
SUPPORT					
	FSA AUFSTECK SHAFT MOUNTED	FS ABTRIEBSWELLE OUTPUT SHAFT	FSS SCHRUMPFSCHEIBE SHRINK DISC	FSZ ABTRIEBSWELLE BEIDSEITIG OUTPUT SHAFT ON BOTH SIDES	
	FLANSCH / FLANGE				
		FFA AUFSTECK SHAFT MOUNTED	FF ABTRIEBSWELLE OUTPUT SHAFT	FFS SCHRUMPFSCHEIBE SHRINK DISC	

4

Bezeichnung	Kennz. Note	Designation
Getriebegröße	G4	Size of the gear unit

Aufsteckgetriebe	46	56	66	76	86	Shaft mounted gear unit
Flachgetriebe	111	131	137			Parallel shaft gear unit

Bezeichnung	Kennz. Note	Designation
Zahnradstufencode	G5	Gear stages code

Aufsteckgetriebegrößen 46, 56, 66, 76, 86
Flachgetriebegrößen 111, 131

Shaft mounted gear unit sizes 46, 56, 66, 76, 86
Parallel shaft gear unit sizes 111, 131

2-stufig	A, S	2-stages
3-stufig (mit Deckelgetriebe)	C	3-stages (with compact gear unit)
4-stufig (mit Deckelgetriebe)	D	4-stages (with compact gear unit)
5-stufig (mit Deckelgetriebe)	F	5-stages (with compact gear unit)

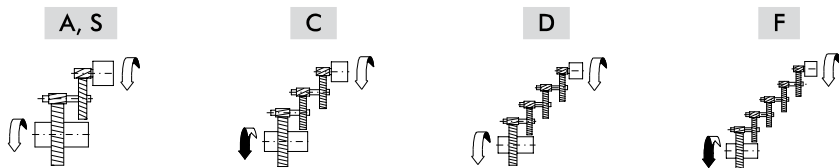

Flachgetriebegröße 137

Parallel shaft gear unit size 137

3-stufig	A	3-stages
4-stufig (mit Deckelgetriebe)	C	4-stages (with compact gear unit)
5-stufig (mit Deckelgetriebe)	D	5-stages (with compact gear unit)

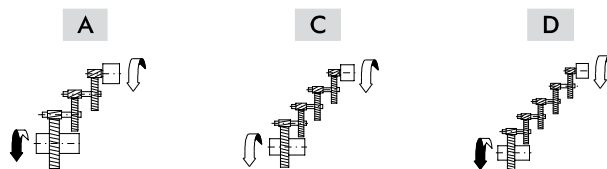

Bezeichnung	Kennz. Note	Designation
Eintriebsart	M	Input type

Getriebeanbaumotor B5-spezial (Bspl. 70 101L4)	70 101L4	Integral motor B5-special (e. g. 70 101L4)
IEC-Adapter mit Flanschmotor B5	IAK 70 101L4	IEC adapter with flange mounted motor B5
Adapter für IEC-Motor (Bspl. IEC-Baugröße 100)	IAK100	Adapter for IEC motors (e.g. IEC frame size 100)
Adapter für SERVO-Motor (Bspl. Größe 142)	SA142	Adapter for SERVO motors (e.g. size 142)
Adapter für NEMA-Motor (Bspl. Größe 56)	NA56	Adapter for NEMA motors (e.g. size 56)
Antriebswelle	WN	Input shaft
Motordirektanbau	IEC200	Direct motor fixing

AUFSTECKGETRIEBEMOTOR A.. 46. - 86.

SHAFT MOUNTED GEARED MOTOR A.. 46. - 86.

70 101L4	IAK100	SA142	NA56	WN	IEC200
Motor siehe Seite 569. Motor see page 569.	Eintriebsvarianten siehe Seite 493. Input types see page 493.				

FLACHGETRIEBEMOTOR F. 111. - 137.

PARALLEL SHAFT GEARED MOTOR F. 111. - 137.

70 101L4	IAK100	SA142	NA56	WN	IEC200
Motor siehe Seite 569. Motor see page 569.	Eintriebsvarianten siehe Seite 493. Input types see page 493.				

Beispiel Example

1 2 3 4
H 3 0 1

Bezeichnung	Stelle Position	Designation
Lage der Abtriebswelle Horizontal H Vertikal V	1	Position of the output shaft Horizontal H Vertical V
Im Raum untenliegende Getriebeseite Seite 1, 2, 3, 4, 5 oder 6	2	Gear unit surface facing down Side 1, 2, 3, 4, 5 or 6
Seite der Abtriebswelle bzw. Wellenausführung Seite der Abtriebswelle 5 oder 6 Hohlwelle 0 mit beidseitiger Abtriebswelle 7	3	Side of output Shaft e.g. shaft type Side of the output shaft 5 or 6 Hollow shaft 0 with output shaft on both sides 7
Befestigungsfläche Seite 1, 2, 3 oder 6	4	Mounting surface Side 1, 2, 3 or 6

4

AUFSTECKGETRIEBEMOTOR A.. 46. - 86.

SHAFT MOUNTED GEARED MOTOR A.. 46. - 86.

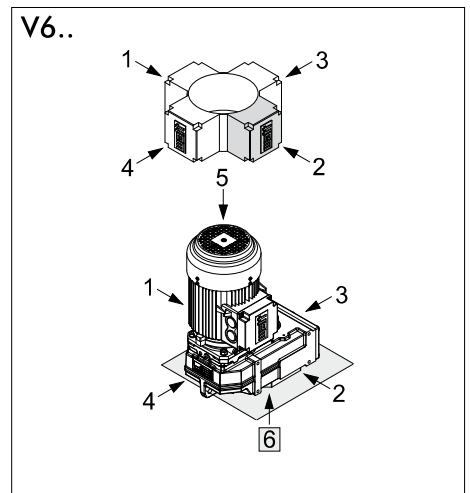
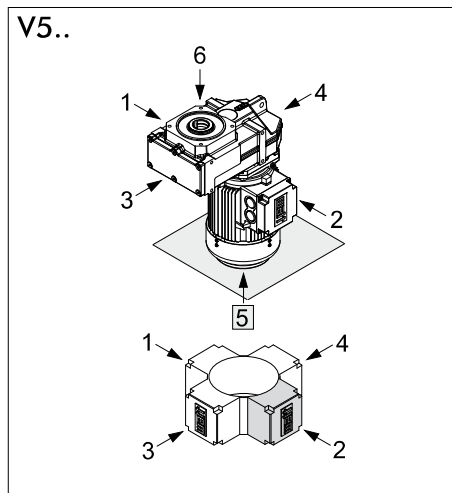
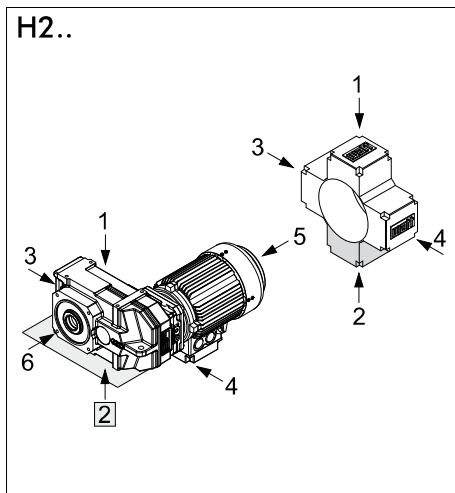
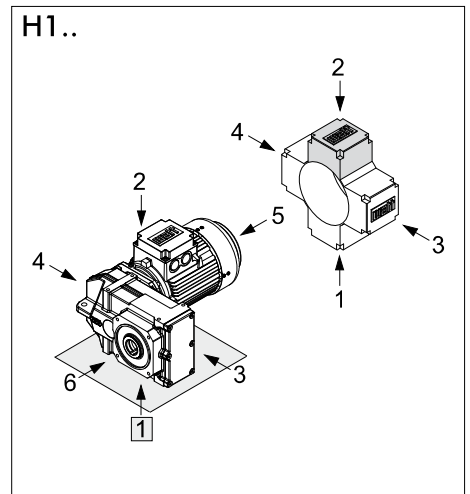
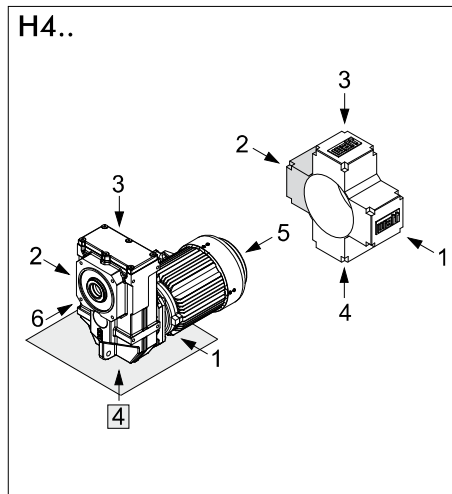
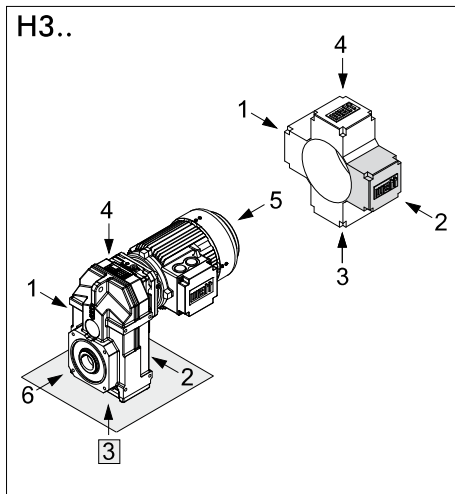

FLACHGETRIEBEMOTOR F. 111. - 137.

PARALLEL SHAFT GEARED MOTOR F. 111. - 137.

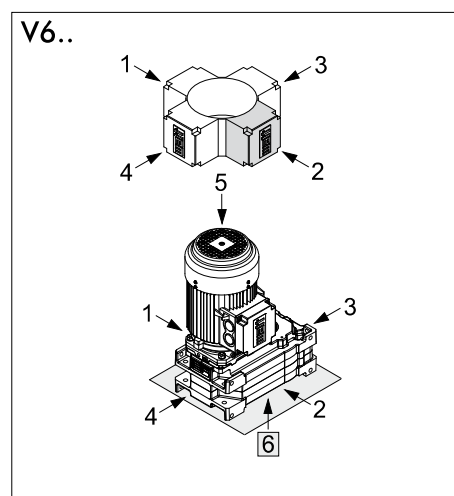
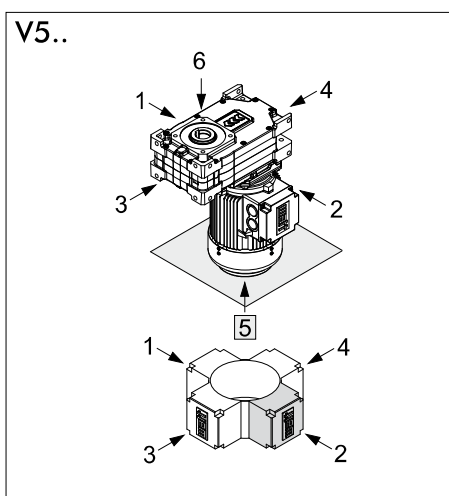
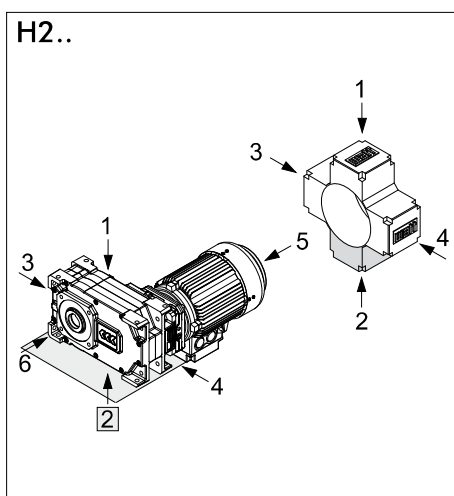
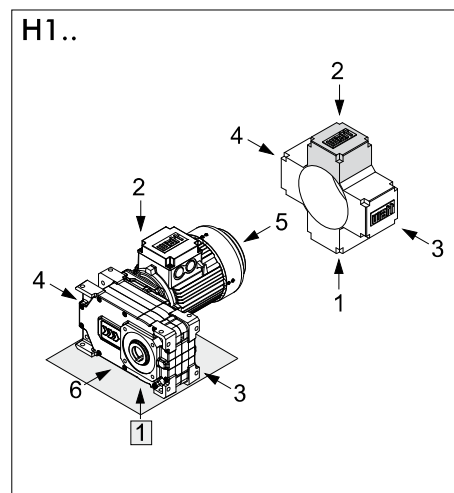
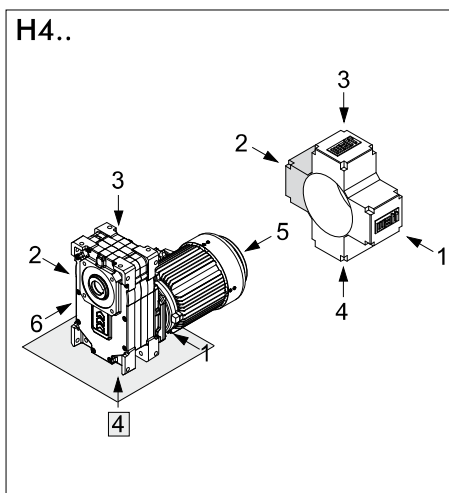
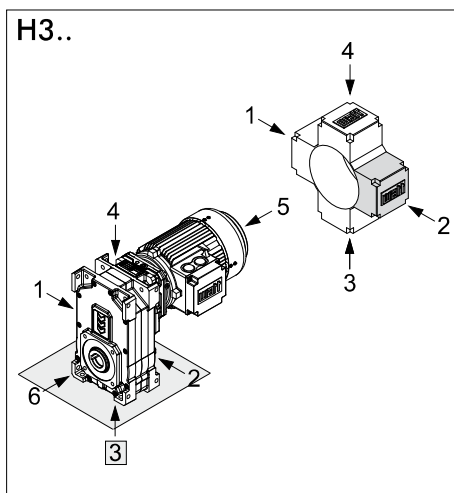

Bezugsfläche
 Reference surface

Der Motorklemmkasten wird standardmäßig auf Seite 2 (grau markiert) montiert. Weicht die gewünschte Position vom Standard ab, ist die Lage nach den oben abgebildeten Beispielen anzugeben.

It is standard to fit the motor terminal box on side 2 (marked grey). However if the terminal box is required on another side, this should be specified from the above example.

GETRIEBEENTLÜFTUNG A.. 76., A.. 86.

Bei den Aufsteckgetriebegrößen A.. 46., A.. 56. und A.. 66. sind keine Entlüftungs-, Ölstands- und Ablassschrauben vorhanden. Diese Typen sind lebensdauergeschmiert.
Bei den Aufsteckgetriebegrößen A.. 76. und A.. 86. werden im Standard, Entlüftungsschrauben mit Transportsicherung (Bild 1) verwendet. Die Gummilasche der Entlüftungsschraube ist vor der Inbetriebnahme komplett abzureißen.
Die Entlüftungsschraube ist an der der Bauform entsprechenden Position eingeschraubt.

DEAREATION THE GEAR UNIT A.. 76., A.. 86.

The shaft mounted gear units sizes A.. 46., A.. 56. and A.. 66.. have no venting, oil level and oil drain plug. These types are supplied with lifetime-lubrication.
The shaft mounted gear units sizes A.. 76. and A.. 86. have a vent plug with transport locking device (Fig. 1) in standard.
The rubber strip on the vent plug must be completely torn off before the unit is put into operation.
The vent plug is placed at the proper position for the mounting position.



Bild 1 / Fig. 1

4

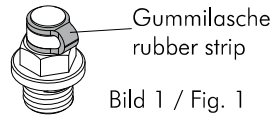
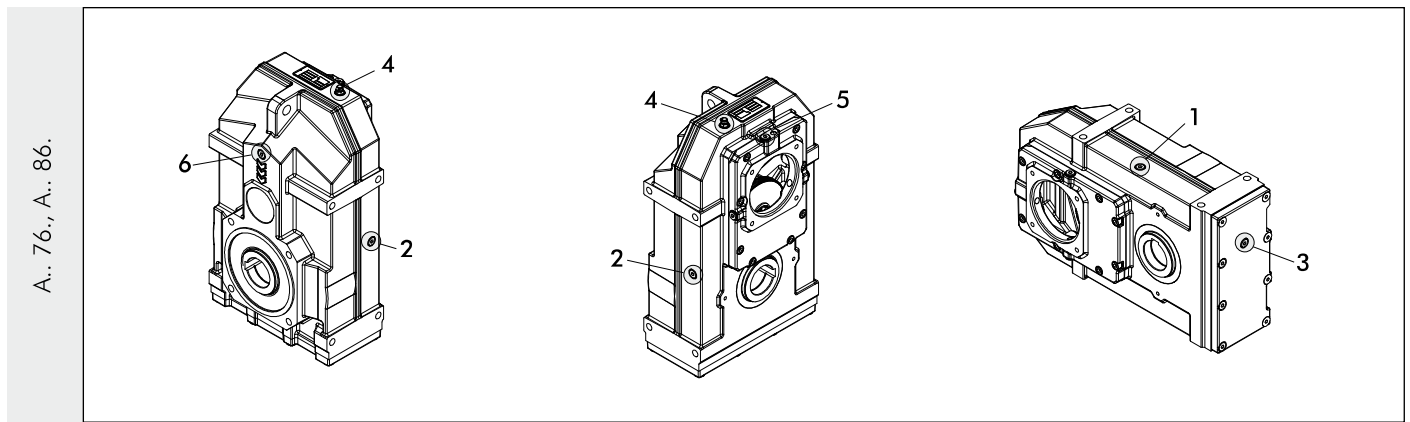

Type	Baupform / Mounting position																	
	H3..			H4..			H1..			H2..			V5..			V6..		
	E	A	S	E	A	S	E	A	S	E	A	S	E	A	S	E	A	S
A.. 76.	4	3	-	3	4	-	2	1	-	1	2	-	6	5	-	5	6	-
A.. 86.	4	3	-	3	4	-	2	1	-	1	2	-	6	5	-	5	6	-

E ... Entlüftungsschraube / vent plug
A ... Ölablassschraube / oil drain plug
S ... Ölstandsschraube / oil level plug

1,2,3,4,5,6 mögliche Positionen der Entlüftungs-, Ölablass- und Ölstandsschraube
possible positons for the vent, oil drain and oil level plug

GETRIEBEENTLÜFTUNG F. 111. - 137.

Bei den Flachgetriebegrößen F. 111., F. 131. und F. 137. werden im Standard, Entlüftungsschrauben mit Transportsicherung (siehe Seite 184 - Bild 1) verwendet. Die Gummilasche der Entlüftungsschraube ist vor der Inbetriebnahme komplett abzureißen. Die Entlüftungsschraube ist an der der Bauform entsprechenden Position eingeschraubt.

DEAREATION THE GEAR UNIT F. 111. - 137.

The parallel shaft gear units sizes F. 111., F. 131. and F. 137. have a vent plug with transport locking device (see page 184 - Fig. 1) in standard. The rubber strip on the vent plug must be completely torn off before the unit is put into operation. The vent plug is placed at the proper position for the mounting position.

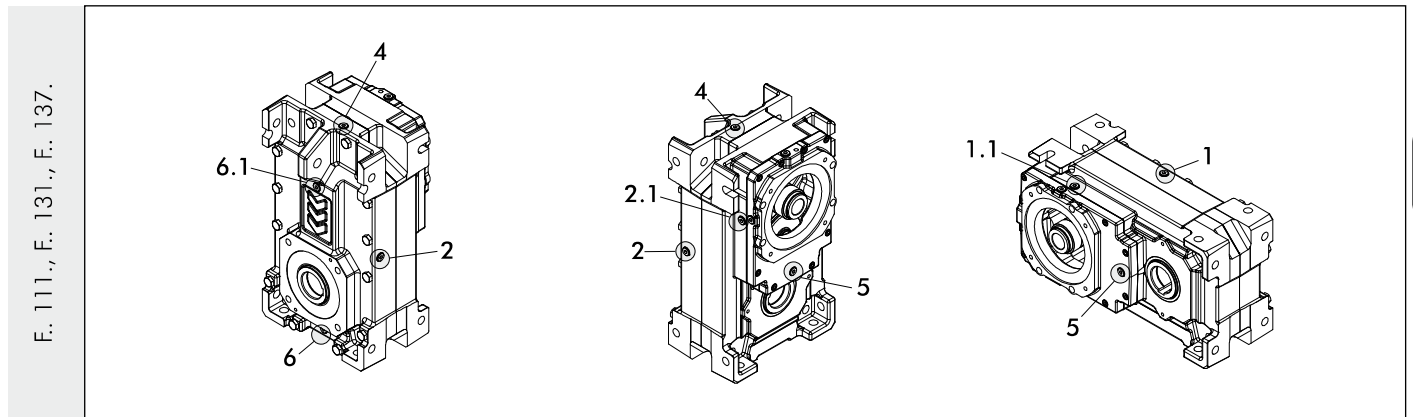

Type	Bauform / Mounting position																	
	H3..			H4..			H1..			H2..			V5..			V6..		
	E	A	S	E	A	S	E	A	S	E	A	S	E	A	S	E	A	S
F. 111.	4	6	6.1	6	4	-	2	1	6	1	2	6	6.1	5	-	5	6	2.1
F. 131.	4	6	6.1	6	4	-	2	1	6	1	2	6	6.1	5	-	5	6	2.1
F. 137.	4	6	6.1	6	4	-	2	1	6	1	2	6	6.1	5	-	5	6	2.1

E ... Entlüftungsschraube / vent plug
 A ... Ölablassschraube / oil drain plug
 S ... Ölstandsschraube / oil level plug

1, 1.1, 2, 2.1, 4, 4.1, 5, 6, 6.1 mögliche Positionen der Entlüftungs-, Ölablass- und Ölstandsschraube
 possible positons for the vent, oil drain and oil level plug

KABELEINFÜHRUNG

Im Standard werden keine Anbauverschraubungen montiert bzw. mitgeliefert.

CABLE ENTRY

Terminal boxes are not delivered with PG gland in standard.

Motorbaureihe 7WA, 70WA, 7BWA Motor model range 7WA, 70WA, 7BWA			
IEC-Motorbaugröße Frame size	Mögliche Kabeleinführung Possible cable entry	Standard-Kabeleinführung Standard cable entry	auf Mehrpreis möglich against extra charge
63 - 250	I, II, III	I	II, III

Blick auf Motorwellenspiegel
im Uhrzeigersinn.
I entspricht rechts
II entspricht links
III entspricht Lüfterseitig

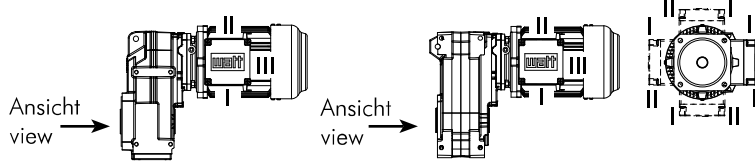

As seen in direction of motor
shaft clockwise.
I corresponds right
II corresponds left
III corresponds fan cover side

Beispiel: Bauform H3
Example: Mounting position H3

4

THERMISCHE GRENZLEISTUNG

Die thermische Grenzleistung P_t muss bei der Auslegung eines Antriebes unbedingt beachtet werden. Sie stellt die maximale Leistung dar, welche bei der jeweiligen Umgebungstemperatur ϑ_∞ im Dauerbetrieb (S1) über das Getriebe übertragen werden kann.

Bei den mit * gekennzeichneten Drehzahlen in den Auswahl-tabellen-Getriebemotoren (Seite 196 bis 232) wird die thermische Grenzleistung P_t bei 20°C Umgebungstemperatur ϑ_∞ (siehe nachfolgende Tabelle 1) überschritten.

In den Auswahl-tabellen-Getriebe (Seite 238 bis Seite 257) ist die maximal zulässige Eintriebsleistung P_{1max} , als mechanische Grenze dargestellt. Eine vorhandene Trennlinie kennzeichnet die Überschreitung der thermischen Grenzleistung P_t bei einer Umgebungstemperatur ϑ_∞ von 20°C.

Die Auslegung der thermischen Grenzleistung P_t erfolgt entsprechend der maximal zulässigen Oberflächentemperatur der Getriebe. Beeinflusst wird die thermische Grenzleistung durch:

- Planschverluste im Schmiermittel, abhängig von Bauform und Umfangsgeschwindigkeit der rotierenden Getriebeteile
- Last- und Drehzahlkollektive
- Umgebungseinflüsse wie Temperatur, Luftzirkulation, Wärmeabfuhr

Als Auslegungswert wird dabei in Standardausführung 80°C Getriebeoberflächentemperatur zugelassen. Durch zusätzliche technische Maßnahmen siehe Faktor f_5 (Seite 189) kann die zulässige Getriebeoberflächentemperatur auf 100°C angehoben werden.

BESTIMMUNG DER MAX. ZULÄSSIGEN EINTRIEBSLEISTUNG (THERMISCHE GRENZE) P_{tzul}

Die max. zulässige Eintriebsleistung P_{tzul} errechnet sich aus der thermischen Grenzleistung P_t und unter Berücksichtigung der Faktoren f_1 bis f_5 .

Der durch die nachfolgende Formel errechnete Wert P_{tzul} gibt jeweils die maximal zulässige Eintriebsleistung des Getriebes an.

$$P_{tzul} = P_t \times f_1 \times f_2 \times f_3 \times f_4 \times f_5 \quad [\text{kW}]$$

THERMAL POWER LIMIT

The thermal power limit P_t must always be taken into account when designing a drive. The thermal power limit P_t represents the maximum input power which can be transmitted by the gear unit at the ambient temperature ϑ_∞ in a continuous operation mode (S1).

In the selection tables for geared motors (page 196 up to 232) the speeds marked with * are those at which the thermal power limit P_t is exceeded at an ambient temperature ϑ_∞ of 20°C (see next table 1).

In the selection tables for gear units (page 238 up to 257) the maximum permissible input power P_{1max} is shown as a physical limit. There is a dividing line showing where the thermal power limit P_t is exceeded at an ambient temperature ϑ_∞ of 20°C.

Exactly how the thermal power limit P_t is interpreted depends on the maximum permissible surface temperature of the gear unit. The thermal power limit is affected by:

- churning losses in the lubricant. These depend on the model and the peripheral speed of the rotating gear parts
- the load and speed profile
- ambient influences such as temperature, air circulation, heat dissipation

For the standard model the design value permits the gear unit a surface temperature of 80°C. There are a number of additional technical measures (see factor f_5 on page 189) that can be taken: these can extend the permitted surface temperature of the gear unit as far as 100°C.

DETERMINING THE MAXIMUM PERMISSIBLE INPUT POWER (THERMAL LIMIT) P_{tzul}

The maximum permissible input power P_{tzul} is calculated from the thermal power limit P_t under consideration of factors f_1 to f_5 .

In each case the value P_{tzul} given by the following formula is the maximum permissible input power for the gear.

P_t Tabelle 1: Thermische Grenzleistung P_t

P_t Table 1: Thermal power limit P_t

Aufsteckgetriebemotor A.. 46A,S - 86A,S

Shaft mounted geared motor A.. 46A,S - 86A,S

Umgebungstemp. Ambient temp. θ _∞	Thermische Grenzleistung P _t in kW Thermal power limit P _t in kW				
	A.. 46A,S	A.. 56A,S	A.. 66A,S	A.. 76A,S	A.. 86A,S
-20°C	7,8	11,0	24,0	40,2	61,2
-10°C	6,7	9,5	20,7	34,7	52,8
0°C	5,7	8,1	17,6	29,5	44,9
10°C	4,8	6,8	14,7	24,6	37,4
20°C	3,9	5,6	11,9	20,1	30,5
30°C	3,1	4,4	9,4	15,9	24,0
40°C	2,4	3,3	7,1	11,9	18,1
50°C	1,8	2,4	5,0	8,3	12,6
60°C	1,2	1,4	3,1	5,1	7,7

Flachgetriebemotor F. 111A,S - 137A

Parallel shaft geared motor F. 111A,S - 137A

Umgebungstemp. Ambient temp. θ _∞	Thermische Grenzleistung P _t in kW Thermal power limit P _t in kW		
	F. 111A,S	F. 131A,S	F. 137A
-20°C	110	140	130
-10°C	95	121	112
0°C	81	103	95
10°C	67	86	79
20°C	55	70	65
30°C	44	56	51
40°C	33	42	39
50°C	23	30	28
60°C	15	19	17

**Korrekturfaktoren für mehrstufige Getriebe:
Aufsteck- und Flachgetriebegrößen 56C - 131F**

**Factor for multistage gear unit:
Shaft mounted and parallel shaft gear unit s. 56C - 131F**

3-stufig (mit Deckelgetriebe)	C	P_t x 0,60	3-stages (with compact gear unit)
4-stufig (mit Deckelgetriebe)	D	P_t x 0,41	4-stages (with compact gear unit)
5-stufig (mit Deckelgetriebe)	F	P_t x 0,30	5-stages (with compact gear unit)

**Korrekturfaktoren für mehrstufige Getriebe:
Flachgetriebegröße 137C,D**

**Factor for multistage gear unit:
Parallel shaft gear unit size 137C,D**

4-stufig (mit Deckelgetriebe)	C	P_t x 0,68	4-stages (with compact gear unit)
5-stufig (mit Deckelgetriebe)	D	P_t x 0,49	5-stages (with compact gear unit)

Beispiel: A.. 86C bei Umgebungstemperatur 20°C

Example: A.. 86C at ambient temperature 20°C

P_t aus Tabelle 1 = 30,5 kW
Korrekturfaktor = 0,60

P_t from table 1 = 30,5 kW
Factor = 0,60

P_t = 30,5 kW x 0,60 = 18,3 kW

P_t = 30,5 kW x 0,60 = 18,3 kW

f₁ Eintriebsvarianten

Bei Getrieben mit IEC - Adaptern gilt die Normleistung der jeweiligen Motorbaugröße nach DIN EN 50347, maximal jedoch die Werte für thermische Grenzleistungen P_T entsprechend der jeweiligen Getriebebaugröße.

Die Werte des Faktors f_1 der verschiedenen Eintriebsvarianten entnehmen Sie aus der nachfolgenden Tabelle.

Getriebemotor	1,00	f ₁
IEC-Adapter (IA)	0,75	
NEMA-Adapter (NA)	0,75	
SERVO-Adapter (SA)	0,75	
Antriebswelle (WN)	0,75	

f₂ Einfluss der Bauform

Bei Antrieben wie z.B. bei der Bauform Motor vertikal nach unten/oben reduzieren sich die zulässigen thermischen Grenzleistungen auf 80% (Faktor f_2), da die erste Verzahnungsstufe voll in das Schmiermittel eintaucht und somit höhere Planschverluste verursacht.

Bauform H3, H1, H2	1,00	f ₂
Bauform H4, V5, V6	0,80	

f₃ Einfluss der Drehzahl

Die Eintriebsdrehzahlen n_1 der angebauten Eintriebsvarianten wird durch den Anwendungsfaktor f_3 berücksichtigt.

$n_1 < 1800$ U/min	1,00	f ₃
$n_1 > 1800$ U/min	0,80	

f₄ Einfluss der Betriebsart

In Abhängigkeit von der Betriebsart und Einschaltdauer ist der Anwendungsfaktor f_4 entsprechend der nachfolgenden Tabelle zu bestimmen.

S1	S3 ... S6 Einschaltdauer bei 60min Betrieb				f ₄
	40min	30min	20min	10min	
1	1,2	1,3	1,5	2	

f₅ Hochtemperatur-Ausführung

Durch Sondermaßnahmen am Getriebemotor kann die zulässige Eintriebsleistung um den nachfolgenden Faktor f_5 erhöht werden. Die Getriebegehäusetemperatur kann jedoch bis zu 100°C ansteigen.

Standard-Getriebemotor	1,00	f ₅
Hochtemperatur-Ausführung	1,50	

f₁ Input types

For gear units with IEC adapters the standard power level for the particular size of motor complies with DIN EN 50347 and is additionally limited by the value of the thermal power limit P_T for the particular type of gear.

The values of the factor f_1 of the various input types see below in the table.

Geared motor	1,00	f ₁
IEC adapter (IA)	0,75	
NEMA adapter (NA)	0,75	
SERVO adapter (SA)	0,75	
Input shaft (WN)	0,75	

f₂ Influence of the mounting position

In the case of drives with, for example, the motor set vertically at the top or bottom, the permissible thermal power limits are reduced to 80% of the values shown (factor f_2) because the first gear reduction stage is entirely immersed in the lubricant and therefore generates higher churning losses.

Mounting pos. H3, H1, H2	1,00	f ₂
Mounting pos. H4, V5, V6	0,80	

f₃ Influence of the speed

The input speed n_1 of the various input types is taken into account by application factor f_3 .

$n_1 < 1800$ rpm	1,00	f ₃
$n_1 > 1800$ rpm	0,80	

f₄ Influence of the mode of operation

The application factor f_4 should be determined from the following table. It depends on the type of operation and the working time, i.e. the time for which the drive is switched on.

S1	S3 ... S6 Working time for 60min operation				f ₄
	40min	30min	20min	10min	
1	1,2	1,3	1,5	2	

f₅ High temperature execution

The permissible input power can be increased by special measures at the geared motor, but this may cause the gear housing temperature to rise as far as 100°C.

Standard-Geared motor	1,00	f ₅
High temperature execution	1,50	

Das Verdrehspiel "s" ergibt sich aus Zahnflankenspiel sowie axialem Spiel der schrägverzahnten Getriebeteile.
Es wird am Abtrieb bei festgesetzter Motor- oder Getriebeantriebswelle mit geringem Drehmoment gemessen.
Das Zahnflankenspiel ist für störungsfreies Abwälzen notwendig.

Aus sämtlichen Fertigungstoleranzen ergibt sich ein Verdrehspielbereich dessen obere Grenze "s_{max}" und untere Grenze "s_{min}" durch Anwendung des Prozentsatzes p₁ aus Tabelle V1 und V2 errechnet wird.

Das angegebene Verdrehspiel aus Diagramm V1 und V2 ist der entsprechende Mittelwert für Standardauslieferung.

Durch einfache Montagemaßnahmen im WATT-Montagewerk kann das Verdrehspiel auf den Wert p₂ verringert werden. Ober- und Untergrenze des verringerten Verdrehspiels "s_r" können durch Anwendung des Prozentsatzes p₃ aus Tabelle V1 und V2 errechnet werden.

Backlash "s" is caused by tooth flank clearance and an axial movement in the bearings caused by the oblique helical gear parts. It is measured with the motor or input shaft fixed at low torque. Tooth flank clearance is important for trouble-free roll out.

A backlash range can be determined from all the manufacturing tolerances. The upper "s_{max}" and lower "s_{min}" limits are calculated using percentage p₁ in table V1 and V2.

The backlash given in diagram V1 and V2 is the relevant mean for standard models.

At the WATT plant we can take simple steps during assembly to reduce the backlash to percentage p₂.

The upper and lower limits for the reduced backlash "s_r" can then be calculated by using percentage p₃ from table V1 and V2.

4

Diagramm V1

Diagram V1

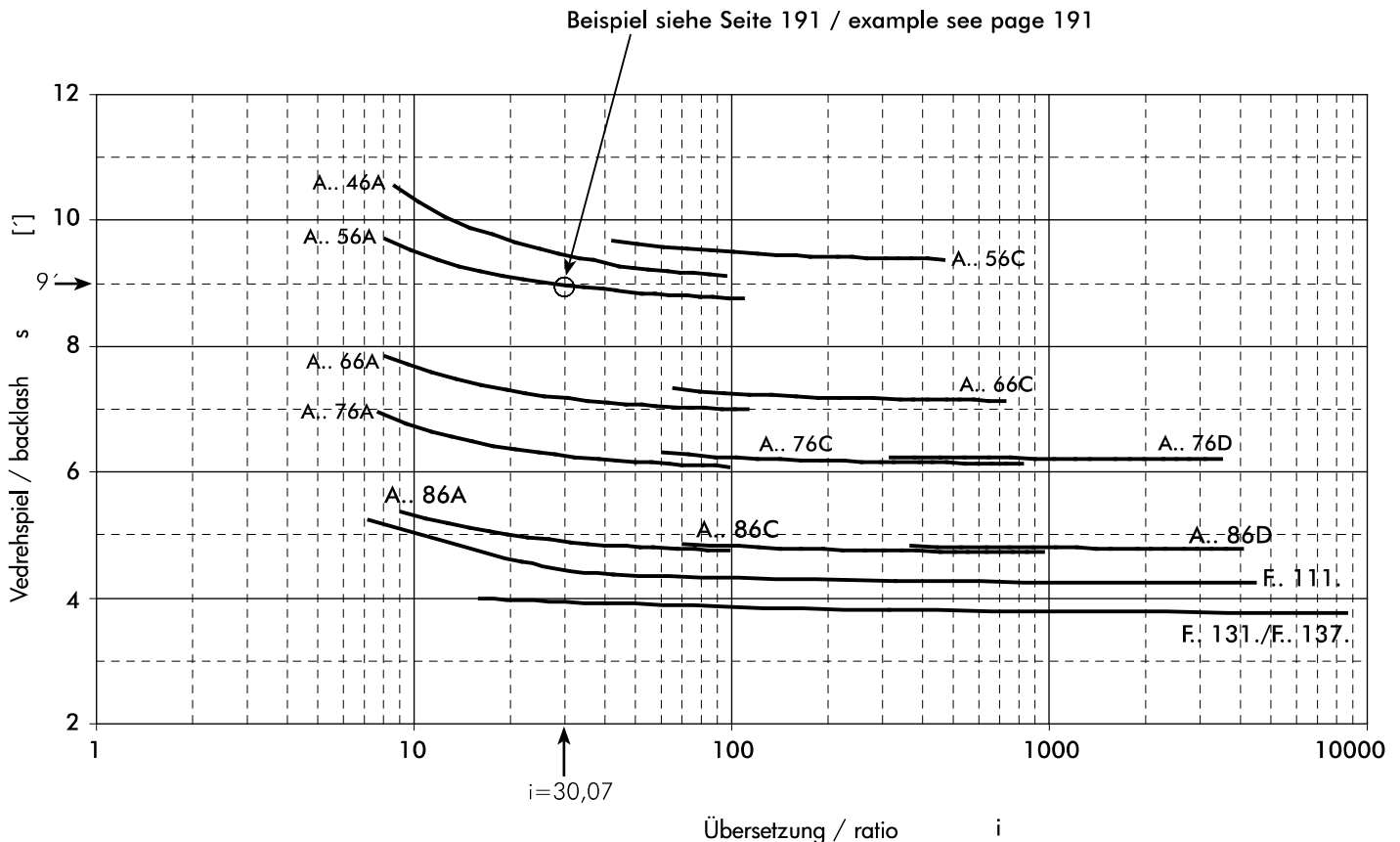

['] Winkelminute / Angular minute

Tabelle V1

Table V1

	A.. 46A	A.. 56A,C	A.. 66A,C	A.. 76A,C,D	A.. 86A,C,D	F. 111A,C,D,F	F. 131A,C,D,F	F. 137A,C,D
p ₁	±33%	±28%	±28%	±28%	±28%	±15%	±15%	±18%
p ₂	72%	79%	79%	79%	79%	100%	100%	100%
p ₃	±17%	±16%	±16%	±16%	±16%	±15%	±15%	±18%

Diagramm V2

Diagramm V2

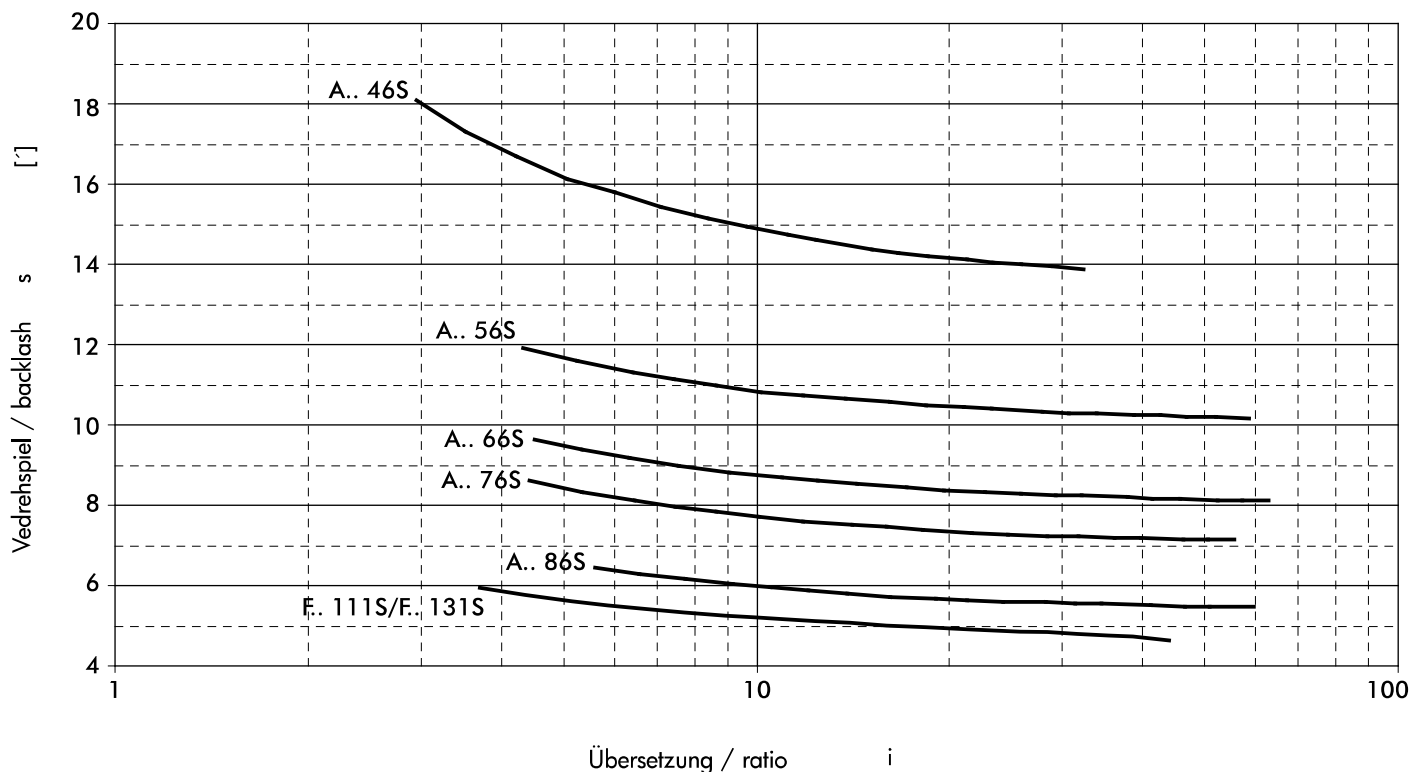

['] Winkelminute / Angular minute

Tabelle V2

Table V2

	A.. 46S	A.. 56S	A.. 66S	A.. 76S	A.. 86S	F. 111S	F. 131S
p ₁	±33%	±27%	±27%	±26%	±26%	±15%	±15%
p ₂	72%	81%	81%	82%	82%	100%	100%
p ₃	±17%	±16%	±16%	±16%	±16%	±15%	±15%

Berechnungsformeln / calculation formulas:		
$s_{max} = s + p_1$	$s_r = s \times p_2$	$s_{rmax} = s_r + p_3$
$s_{min} = s - p_1$		$s_{rmin} = s_r - p_3$

Beispiel / example:					
A.. 56A ...	i=30,07	Diagramm V1	→	s = 9'	Tab. V1
					$s_{max} = s + p_1$
					$s_{max} = 9' + 28%$
					→ s _{max} = 11,5'
					$s_{min} = s - p_1$
					$s_{min} = 9' - 28%$
					→ s _{min} = 6,5'
Reduziertes Verdrehspiel / reduced backlash:					
Tab. V1	→	$s_r = s \times p_2$		Tab. V1	$s_{rmax} = s_r + p_3$
		$s_r = 9' \times 79%$			$s_{rmax} = 7,1' + 16%$
		$s_r = 7,1'$			→ s _{rmax} = 8,2'
					$s_{rmin} = s_r - p_3$
					$s_{rmin} = 7,1' - 16%$
					→ s _{rmin} = 6,0'

Die im jeweiligen Getriebekapitel angegebenen Querkräfte (F_{rN}) gelten bei Kraftangriff auf Wellenmitte ($x = l/2$). Bei der Ermittlung der zulässigen Querkräfte wurde die ungünstigste Kraftangriffsrichtung angenommen. Die Berechnung erfolgte mit Standardwelle und Standardlagerung.

Andere Krafrichtung und Kraftangriff können mit den entsprechenden Gleichungen Gl. Q1 bis Q3 berechnet werden.

Werden auf die Abtriebswelle Übertragungselemente aufgesetzt, so ist bei der Ermittlung der auftretenden Querkraft ein entsprechender Faktor (f_z) zu beachten.

The overhung loads (F_{rN}) indicated in the relevant transmission section apply to foot and flange gears with the force acting on the shaft center ($x = l/2$). The permissible overhung loads listed are based on the least favorable loading direction and calculated for standard shafts and standard bearings.

Other load directions and action can be calculated with equations Gl. Q1 and Gl. Q2. If transmission elements are placed on the output shaft, an appropriate factor (f_z) has to be taken into consideration when determining the overhung load.

Zahnräder / gear wheels	Kettenräder / sprockets	Keilriemen / V-belts	Flachriemen / Flat belts
$f_z = 1,1 \quad (z \leq 17)$	$f_z = 1,2 \quad (z \leq 13)$ $f_z = 1,1 \quad (z > 13)$	$f_z = 1,8$	$f_z = 2,5$

4

Mit den nachfolgenden Gleichungen (Gl. Q1 bis Q3) können die zulässigen Radialkräfte an der Getriebeabtriebswelle ermittelt werden.

Mit der Gl. Q4 können die tatsächlich auftretenden Wellenbelastungen errechnet werden.

Die Ergebnisse sind entsprechend Gl. Q5 zu vergleichen.

Use the following equations (Gl. Q1 up to Q3) to calculate the permissible radial loads on the output shaft.

Use the Gl. Q4 to calculate the real existing shaft loads for your application.

The results are to compare by using the equation Gl. Q5.

$F_{zL} = F_{rN} \times a_1 \times a_3$	Gl. Q1
---	--------

a_1 [-] ... Kraftangriffsfaktor - **Abtriebswellenlagerung** aus Tabelle 1 / load action factor - **output shaft bearing** from table 1

$F_{zW} = F_W \times a_2$	Gl. Q2
---------------------------	--------

a_2 [-] ... Kraftangriffsfaktor - **Abtriebswelle** aus Tabelle 1 / load action factor - **output shaft** from table 1

a_3 [-] ... Krafrichtungsfaktor aus Gl. Q3 / load direction factor from Equation Gl. Q3

$a_3 = f_1^{f_2 \times f_3}$	Gl. Q3
------------------------------	--------

d_0 [m] ... Wirkdurchmesser des Übertragungselementes / effective diameter of the transmission element

M_2 [Nm] ... Abtriebsdrehmoment des Getriebemotors (aus Auswahltabellen) bzw. benötigtes Abtriebsmoment / geared motor output torque (from selection tables) or required calculated output torque

$F_{Qvorh} = \frac{2 \times M_2}{d_0} \times f_z$	Gl. Q4
---	--------

F_{zL} [N] ... Zulässige Querkraft für **Abtriebswellenlagerung** / permissible overhung load for **output shaft bearings**

F_{zW} [N] ... Zulässige Querkraft für **Abtriebswelle** / permissible overhung load for **output shaft**

F_{rN} [N] ... Zulässige Querkraft aus Auswahltabellen (Seite 196 bis 232) / permissible overhung load from selection tables (page 196 up to 232)

F_W [N] ... Zulässige Querkraft - **Abtriebswelle** $x = l/2$ aus Tabelle 3 und 3.1 / permissible overhung load - **output shaft** $x = l/2$ from table 3 and 3.1

F_{Qvorh} [N] ... Vorhandene Querkraft an der Getriebewelle / existing overhung load at gear shaft

f_z [-] ... Faktor für Übertragungselement (siehe oben) / factor for transmission element (see above)

M_{max} [Nm] ... Max. mögliches Abtriebsdrehmoment für Kupplungsbetrieb (Tabelle 3 und 3.1) / max. possible output torque for coupling operation (table 3 and 3.1)

es gilt:
valid:

$F_{Qvorh} \leq F_{zL}$	Gl. Q5
$F_{Qvorh} \leq F_{zW}$	

f_1 [-] ... Wirkrichtungsfaktor / direction factor

f_2 [-] ... Faktor für f_B / direction factor for f_B

f_3 [-] ... Abtriebsdrehzahlfaktor / output speed factor

} aus Tabelle 2 / from table 2

Grundsätzlich muß nach Gl. Q1 als auch Gl. Q2 gerechnet werden.

Both Gl. Q1 and Gl. Q2 should always be used in calculations.

Tabelle / table 1 Kraftangriffsfaktoren / Load action factors a_1, a_2 :

		x / l				
0	0,25	0,5	0,75	1	1,5	2
		$a_1 \rightarrow$ Gl. Q1				
1,39	1,18	1,00	0,85	0,73	0,52	0,38
		$a_2 \rightarrow$ Gl. Q2				
2,00	2,00	1,00	0,55	0,38	0,23	0,17

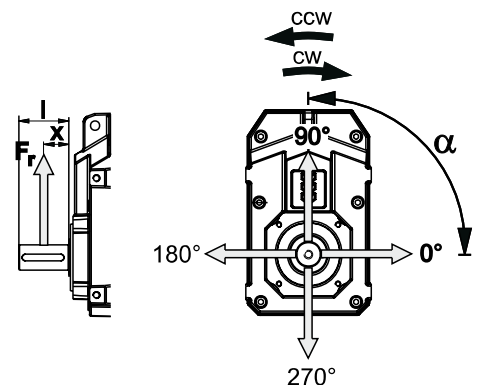

Faktoren / Factors f_1, f_2, f_3 :

Tabelle 2
table 2

	Wirkrichtung Direction				Wirkrichtung Direction				Betriebsfaktor Service factor					Abtriebsdrehzahl Output speed					
	α				α				f_B					n_2 [min ⁻¹]					
	0°	90°	180°	270°	0°	90°	180°	270°	1	1,25	1,5	2	3	150	100	75	50	25	10
	$f_1 \rightarrow$ Gl. Q3								$f_2 \rightarrow$ Gl. Q3					$f_3 \rightarrow$ Gl. Q3					
A.. 46.	1,00	1,17	1,17	1,00	1,17	1,06	1,00	1,11	1,51	1,20	1	0,75	0,49	1,45	1,27	1,15	1	0,79	0,58
A.. 56., A.. 66.	1,00	1,22	1,23	1,01	1,24	1,10	1,00	1,13	1,52	1,21	1	0,74	0,49	1,46	1,27	1,15	1	0,79	0,58
A.. 76.	1,00	1,34	1,37	1,02	1,38	1,16	1,01	1,20	1,55	1,21	1	0,74	0,49	1,48	1,28	1,15	1	0,79	0,57
A.. 86.	1,00	1,42	1,43	1,01	1,45	1,17	1,02	1,26	1,57	1,22	1	0,74	0,48	1,50	1,29	1,16	1	0,78	0,57

4

Faktoren / Factors f_1, f_2, f_3 :

Tabelle 2
table 2

	Wirkrichtung Direction				Wirkrichtung Direction				Betriebsfaktor Service factor					Abtriebsdrehzahl Output speed					
	α				α				f_B					n_2 [min ⁻¹]					
	0°	90°	180°	270°	0°	90°	180°	270°	1	1,25	1,5	2	3	150	100	75	50	25	10
	$f_1 \rightarrow$ Gl. Q3								$f_2 \rightarrow$ Gl. Q3					$f_3 \rightarrow$ Gl. Q3					
F. 111.	1,00	1,50	1,53	1,02	1,55	1,22	1,02	1,30	1,59	1,22	1	0,73	0,48	1,51	1,29	1,16	1	0,78	0,57
F. 131.	1,00	1,69	1,74	1,03	1,78	1,30	1,04	1,42	1,58	1,24	1	0,73	0,47	1,56	1,31	1,17	1	0,77	0,56
F. 137.	1,43	2,18	2,50	2,04	2,50	2,15	1,00	1,60	1,63	1,23	1	0,73	0,48	1,55	1,31	1,17	1	0,77	0,56

Zul. Querkraft - Abtriebswelle / Permissible overhung load - output shaft $x = l/2$

Tabelle 3
table 3

	M_{max} ($F_r = 0$)	Abtriebsdrehmoment / Output torque M_2 [Nm]																	
		25	50	75	100	125	150	180	270	400	560	800	1000	1400	2000	3000	5000	8000	14000
		F_w [N] bei $a/l = 0,5 \rightarrow$ Gl. Q2																	
Ø20x40	160Nm	4100	4000	3800	3500	1600													
Ø25x50	300Nm	6400	6300	6300	6200	6000	5800	5000											
Ø30x60	500Nm		8000	7900	7900	7800	7700	7600	6900	2900									
Ø35x70	770Nm			11700	11700	11700	11600	11500	11300	9900	5900								
Ø40x80	1150Nm					13800	13800	13700	13600	13200	12400	9000							
Ø45x90	1590Nm						15500	15500	15400	15100	14600	13500	11600						
Ø50x100	2190Nm							20100	20100	20000	19800	19500	18900	18100	15400				
Ø55x110	2910Nm									25300	25000	24200	23300	20800	13900				
Ø60x120	3780Nm										33600	33000	32400	30500	26100	8000			
Ø65x140	4720Nm												35600	35000	33600	26800			
Ø70x140	5890Nm												41000	40100	38100	32700			
Ø75x140	7250Nm													58000	56200	51500	32000		
Ø90x170	11900Nm														71500	70500	65100	42900	
Ø100x210	15800Nm															68900	66800	61400	
Ø110x210	21000Nm																100800	97300	67500

4

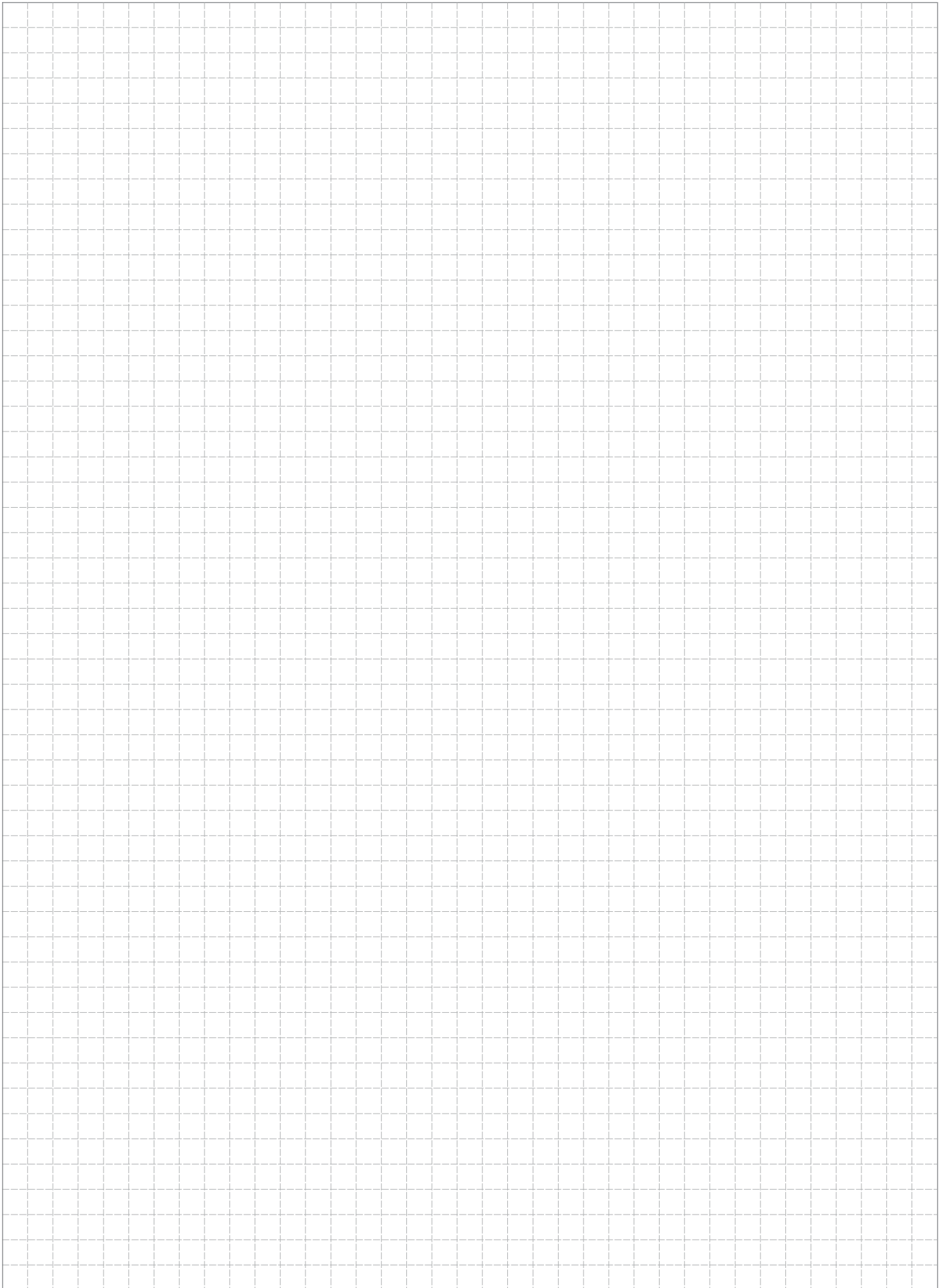

AUFBAU DER AUSWAHLTABELLEN

STRUCTURE OF SELECTION TABLES

Die Auswahltabellen wurden mit folgenden Motordaten gerechnet:

The selection tables are calculated with following motor data:

WATT Type	Motorbaureihe Motor model range
64 - 81 (bis/up to 0,55kW)	7WA
81 (ab/from 0,75kW) - 161	70WA
180 - 250	7BWA

Benutzen Sie unsere Projektierungssoftware „cat4CAD®“. Diese ermöglicht eine zeitsparende, effiziente Antriebskonfiguration des kompletten MAS®-Programms.

Use our interactive product software „cat4CAD®“. It enables a timesaving, efficient drive configuration of the entire MAS® programme.



1 P_N = 0,12 kW / 0,16 HP

50 - 60 - 87 Hz (100 Hz) ¹⁾					60 Hz			bei/at 50 Hz				m kg		ZT Code
0,12 - 0,14 - 0,21 kW (0,24 kW)					0,12 kW			(F _o =0) (F _r =0)						
n ₅₀ min ⁻¹	n ₆₀ min ⁻¹	n ₈₇ min ⁻¹	M ₂ Nm	f _B	n ₆₀ min ⁻¹	M ₂ Nm	f _B	i	F _{rN} kN	F _{aN} kN				
2	3	4	5	6	7	8	9	10	11	12	13	14	15	16

- 1** Nennleistung (Bemessungsleistung) des Motors
- 2** Abtriebsdrehzahl bei 50Hz
- 3** Abtriebsdrehzahl bei 60Hz
- 4** Abtriebsdrehzahl bei 87 oder 100Hz
- 5** Abtriebsdrehmoment bei 50, 60, 87 oder 100Hz
- 6** Betriebsfaktor bei 50, 60, 87 oder 100Hz
- 7** Abtriebsdrehzahl bei 60Hz
- 8** Abtriebsdrehmoment bei 60Hz ohne erhöhter Leistung
- 9** Betriebsfaktor bei 60Hz ohne erhöhter Leistung
- 10** Gesamtübersetzung
- 11** Zul. Querkraft auf Wellenmitte (Standardlagerung) bei Axialkraft=0
- 12** Zul. Axialkraft (Standardlagerung) bei Radialkraft=0
- 13** Typenbezeichnung - Getriebemotor
Typenbezeichnung - Getriebe + IEC-Adapter
Typenbez. - Rührwerksantrieb siehe Seite 482
Typenbez. - Rührwerksantrieb + IEC-Adapter siehe Seite 482
- 14** Gewicht
- 15** Maßbild siehe Seite
- 16** Zahnradteilecode

*) Eine erhöhte Leistung bei 60Hz kann nur bei gleichzeitig erhöhter Spannung innerhalb des Weitbereichs abgenommen werden (Details siehe Erklärung WATT-EUSAS®-Weitbereichswicklung Seite 586):

*) The increased rated power at 60Hz can only be reached together with increased voltage within the wide range (for details see explanation of WATT EUSAS® wide range winding on page 586):



**Erhöhte Leistung
Increased rated power**

1,2 x P_N

¹⁾ 100 Hz Kennlinie bei Motortype 64 und 72 nicht möglich. Motortoleranzbereich lt. Norm IEC 60034.

¹⁾ 100 Hz characteristic for motor type 64 and 72 are not possible. Tolerance of the motor speed according to EN 60034.

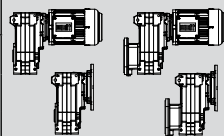
P_N = 0,12 kW / 0,16 HP



50 - 60 - 87 Hz 0,12 - 0,14 - 0,21 kW					60 Hz 0,12 kW			i	bei/at 50 Hz (F _a =0) (F _r =0)			m kg		ZT Code	
n ₅₀ min ⁻¹	n ₆₀ min ⁻¹	n ₈₇ min ⁻¹	M ₂ Nm	f _B	n ₆₀ min ⁻¹	M ₂ Nm	f _B		F _{rN} kN	F _{aN} kN					
1,0	1,2	1,8	1146	1,35	1,2	955	1,60	816,16	17,4	24,5	ASA 76C 64N6 ASA 76C IA63 ARA 76C 64N6 ARA 76C IA63	62	266	0507/09100	
1,2	1,4	2,0	955	1,60	1,4	796	1,90	727,20	18,3	24,5		59	546	0507/10099	
1,3	1,5	2,2	882	1,75	1,5	735	2,05	654,41	18,6	24,5		78	486	0507/11098	
1,4	1,7	2,5	819	1,85	1,7	682	2,20	593,76	18,8	24,5		75	546	0507/12097	
1,5	1,9	2,7	764	2,00	1,9	637	2,40	542,43	19,0	24,5				0507/13096	
1,2	1,4	2,0	955	0,85	1,4	796	1,05	724,07	**	20,3	ASA 66C 64N6 ASA 66C IA63 ARA 66C 64N6 ARA 66C IA63	40	266	0407/09080	
1,3	1,6	2,3	882	0,95	1,6	735	1,10	643,52	6,1	20,3		37	546	0407/10079	
1,5	1,7	2,5	764	1,05	1,7	637	1,30	577,61	10,0	20,3		48	486	0407/11078	
1,6	1,9	2,8	716	1,15	1,9	597	1,35	522,69	11,1	20,3		45	546	0407/12077	
1,8	2,2	3,2	637	1,30	2,2	531	1,55	724,07	12,0	20,3				0407/09080	
2,1	2,5	3,6	546	1,50	2,5	455	1,80	643,52	12,5	20,3	ASA 66C 64K4 ASA 66C IA63 ARA 66C 64K4 ARA 66C IA63	39	266	0407/10079	
2,3	2,8	4,0	498	1,65	2,8	415	1,95	577,61	12,7	20,3		37	546	0407/11078	
2,5	3,1	4,4	458	1,75	3,1	382	2,10	522,69	12,9	20,3		47	486	0407/12077	
2,8	3,4	4,9	409	2,00	3,4	341	2,35	476,22	13,1	20,3		45	546	0407/13076	
					2,2	531	0,80	462,55	**	11,6		ASA 56C 64N6 ASA 56C IA63 ARA 56C 64N6 ARA 56C IA63	25	266	0407/09080
					2,5	478	0,85	411,09	5,4	11,6	22		546	0407/10079	
2,3	2,7	4,0	498	0,85	2,7	415	1,00	368,99	7,8	11,6	30		486	0407/11078	
2,5	3,0	4,4	458	0,90	3,0	382	1,05	333,90	8,8	11,6	27		546	0407/12077	
2,9	3,5	5,0	395	1,05	3,5	329	1,25	462,55	9,9	11,6				0407/09080	
3,2	3,9	5,6	358	1,15	3,9	298	1,35	411,09	10,3	11,6	ASA 56C 64K4 ASA 56C IA63 ARA 56C 64K4 ARA 56C IA63	24	266	0407/10079	
3,6	4,3	6,3	318	1,30	4,3	265	1,55	368,99	10,5	11,6		22	546	0407/11078	
4,0	4,8	6,9	287	1,40	4,8	239	1,70	333,90	10,6	11,6		29	486	0407/12077	
4,4	5,2	7,6	260	1,55	5,2	217	1,85	304,21	10,7	11,6		27	546	0407/13076	
5,0	6,0	8,7	229	1,75	6,0	191	2,10	264,91	10,9	11,6				0410/11056	
5,6	6,7	9,7	205	2,00	6,7	171	2,35	238,50	10,9	11,6		27	546	0410/12055	
6,2	7,4	11	185	2,20	7,4	154	2,60	216,15	11,0	11,6				0410/13054	
7,5	9,0	13	153	2,65	9,0	127	3,15	177,79	11,1	11,6				0412/12041	
8,3	10	15	138	2,90	10	115	3,50	160,11	11,1	11,6				0412/13040	
8,8	11	15	130	1,70	11	109	2,05	95,35	7,8	7,3		ASA 46A 64N6 ASA 46A IA63	18	260	0407/09080
9,9	12	17	116	1,95	12	96	2,30	84,75	7,8	7,3			15	546	0407/10079
11	13	19	104	2,15	13	87	2,55	76,07	7,9	7,3					0407/11078
12	15	21	94	2,35	15	78	2,85	68,83	7,9	7,3					0407/12077
14	17	24	82	2,70	17	69	3,25	95,35	7,9	7,3	ASA 46A 64K4 ASA 46A IA63		18	260	0407/09080
16	19	27	73	3,05	19	61	3,65	84,75	7,9	7,3		15	546	0407/10079	
18	21	30	65	3,40	21	55	4,05	76,07	7,7	7,3				0407/11078	
19	23	34	59	3,75	23	49	4,45	68,83	7,4	7,3				0407/12077	
21	25	37	54	4,10	25	45	4,90	62,71	7,2	7,3				0407/13076	
24	29	42	47	4,70	29	39	5,65	54,61	6,9	7,3				0410/11056	
27	33	47	42	5,25	33	35	6,25	49,17	6,7	7,3				0410/12055	
30	36	52	38	5,75	36	32	6,90	44,56	6,5	7,3				0410/13054	
36	44	63	32	7,00	44	26	8,40	36,65	6,1	7,3				0412/12041	
40	48	70	28	7,75	48	24	9,30	33,01	5,9	7,3				0412/13040	
47	56	81	25	8,95	56	21	10,75	28,61	5,6	7,3				0415/12032	
54	64	93	21	10,30	64	18	12,35	24,81	5,4	7,3				0412/16037	
64	77	111	18	12,25	77	15	14,70	20,86	5,1	7,3				0412/18035	
75	90	131	15	14,45	90	13	17,35	17,70	4,8	7,3				0412/20033	
89	107	155	13	17,10	107	11	20,55	14,94	4,5	7,3				0410/28039	
107	129	186	11	9,75	129	9	11,70	12,42	4,3	7,3	ASA 46S 64K4 ASA 46S IA63	18	260	0412/12041	
119	143	207	10	10,70	143	8	12,85	11,19	4,1	7,2		15	546	0412/13040	
137	165	239	8	12,25	165	7	14,70	9,70	3,9	6,9				0415/12032	
158	190	275	7	14,10	190	6	16,90	8,41	3,8	6,5				0412/16037	
188	226	327	6	16,45	226	5	19,70	7,07	3,5	6,2				0412/18035	
222	266	386	5	17,65	266	4	21,15	6,00	3,4	5,9				0412/20033	
263	315	457	4	18,80	315	4	22,55	5,07	3,2	5,5				0410/28039	
315	378	548	4	20,10	378	3	24,10	4,22	3,0	5,2			0410/31036		

P_N = 0,18 kW / 0,25 HP

50 - 60 - 87 Hz 0,18 - 0,22 - 0,31 kW					60 Hz 0,18 kW			i	bei/at 50 Hz (F _o =0) (F _r =0)			m kg		ZT Code			
n ₅₀ min ⁻¹	n ₆₀ min ⁻¹	n ₈₇ min ⁻¹	M ₂ Nm	f _B	n ₆₀ min ⁻¹	M ₂ Nm	f _B		F _{rN} kN	F _{aN} kN							
1,0	1,2	1,8	1719	1,65	1,2	1433	2,00	850,50	32,4	36,8	ASA 86C 72K6 ASA 86C IA71 ARA 86C 72K6 ARA 86C IA71	104	266	0507/10099			
1,1	1,4	2,0	1563	1,80	1,4	1302	2,20	765,37	33,7	36,8		100	546	0507/11098			
1,3	1,5	2,2	1322	2,15	1,5	1102	2,55	694,43	35,3	36,8		134	486	0507/12097			
												130	546				
1,1	1,3	1,9	1563	1,00	1,3	1302	1,20	816,16	12,0	24,5	ASA 76C 72K6 ASA 76C IA71 ARA 76C 72K6 ARA 76C IA71	63	266	0507/09100			
1,2	1,4	2,1	1433	1,05	1,4	1194	1,30	727,20	14,8	24,5		58	546	0507/10099			
1,3	1,6	2,3	1322	1,15	1,6	1102	1,40	654,41	16,4	24,5		79	486	0507/11098			
1,5	1,8	2,5	1146	1,35	1,8	955	1,60	593,76	17,4	24,5		74	546	0507/12097			
1,6	1,9	2,8	1074	1,40	1,9	895	1,70	542,43	17,8	24,5				0507/13096			
1,6	1,9	2,8	1074	1,40	1,9	895	1,70	816,16	17,8	24,5	ASA 76C 64N4 ASA 76C IA63 ARA 76C 64N4 ARA 76C IA63	61	266	0507/09100			
1,8	2,2	3,2	955	1,60	2,2	796	1,90	727,20	18,3	24,5		59	546	0507/10099			
2,0	2,4	3,5	860	1,75	2,4	716	2,10	654,41	18,7	24,5		77	486	0507/11098			
2,2	2,7	3,9	781	1,95	2,7	651	2,35	593,76	18,9	24,5		75	546	0507/12097			
1,8	2,2	3,2	955	0,85	2,2	796	1,05	724,07	**	20,3	ASA 66C 64N4 ASA 66C IA63 ARA 66C 64N4 ARA 66C IA63	39 37 47 45	266 546 486 546	0407/09080			
2,1	2,5	3,6	819	1,00	2,5	682	1,20	643,52	8,5	20,3				0407/10079			
2,3	2,7	4,0	747	1,10	2,7	623	1,30	577,61	10,4	20,3				0407/11078			
2,5	3,0	4,4	688	1,20	3,0	573	1,40	522,69	11,6	20,3				0407/12077			
2,8	3,3	4,8	614	1,35	3,3	512	1,60	476,22	12,1	20,3				0407/13076			
3,2	3,8	5,5	537	1,50	3,8	448	1,80	414,70	12,5	20,3				0410/11056			
3,5	4,2	6,2	491	1,65	4,2	409	2,00	373,35	12,8	20,3				0410/12055			
3,9	4,7	6,8	441	1,85	4,7	367	2,20	338,37	13,0	20,3				0410/13054			
4,7	5,7	8,3	366	2,20	5,7	305	2,65	278,32	13,3	20,3				0412/12041			
5,3	6,3	9,2	324	2,50	6,3	270	3,00	250,64	13,4	20,3				0412/13040			
6,1	7,3	11	282	2,85	7,3	235	3,45	217,22	13,5	20,3				0415/12032			
					3,4	494	0,85	462,55	4,4	11,6	ASA 56C 64N4 ASA 56C IA63 ARA 56C 64N4 ARA 56C IA63	24 22 29 27	266 546 486 546	0407/09080			
					3,9	448	0,90	411,09	6,7	11,6				0407/10079			
3,6	4,3	6,2	478	0,85	4,3	398	1,05	368,99	8,4	11,6				0407/11078			
4,0	4,7	6,9	430	0,95	4,7	358	1,15	333,90	9,3	11,6				0407/12077			
4,3	5,2	7,5	400	1,05	5,2	333	1,25	304,21	9,9	11,6				0407/13076			
5,0	6,0	8,7	344	1,20	6,0	287	1,40	264,91	10,4	11,6				0410/11056			
5,5	6,6	9,6	313	1,30	6,6	260	1,55	238,50	10,5	11,6				0410/12055			
6,1	7,3	11	282	1,45	7,3	235	1,75	216,15	10,7	11,6				0410/13054			
7,4	8,9	13	232	1,75	8,9	194	2,10	177,79	10,8	11,6				0412/12041			
8,2	9,9	14	210	1,95	9,9	175	2,30	160,11	10,9	11,6				0412/13040			
9,5	11	17	181	2,25	11	151	2,70	138,76	11,0	11,6				0415/12032			
11	13	19	156	2,60	13	130	3,10	120,33	11,1	11,6				0412/16037			
9,1	11	16	189	1,20	11	157	1,40	95,35	7,5	7,3				ASA 46A 72K6 ASA 46A IA71	20 15	260 546	0407/09080
10	12	18	167	1,35	12	139	1,60	84,75	7,6	7,3							0407/10079
11	14	20	151	1,50	14	126	1,80	76,07	7,7	7,3	0407/11078						
13	15	22	136	1,65	15	114	1,95	68,83	7,8	7,3	0407/12077						
14	17	24	124	1,80	17	103	2,15	62,71	7,8	7,3	0407/13076						
14	17	24	125	1,80	17	104	2,15	95,35	7,8	7,3	ASA 46A 64N4 ASA 46A IA63	18 15	260 546	0407/09080			
16	19	27	110	2,00	19	92	2,40	84,75	7,8	7,3				0407/10079			
17	21	30	99	2,25	21	82	2,70	76,07	7,6	7,3				0407/11078			
19	23	33	90	2,50	23	75	2,95	68,83	7,3	7,3				0407/12077			
21	25	37	82	2,70	25	68	3,25	62,71	7,1	7,3				0407/13076			
24	29	42	71	3,10	29	59	3,75	54,61	6,8	7,3				0410/11056			
27	32	47	64	3,45	32	53	4,15	49,17	6,6	7,3				0410/12055			
30	36	52	58	3,80	36	48	4,55	44,56	6,4	7,3				0410/13054			
36	43	63	48	4,65	43	40	5,55	36,65	6,0	7,3				0412/12041			
40	48	70	43	5,15	48	36	6,15	33,01	5,8	7,3				0412/13040			
46	55	80	37	5,90	55	31	7,10	28,61	5,6	7,3				0415/12032			
53	64	93	32	6,85	64	27	8,20	24,81	5,3	7,3				0412/16037			
63	76	110	27	8,15	76	23	9,75	20,86	5,0	7,3				0412/18035			
75	90	130	23	9,55	90	19	11,50	17,70	4,8	7,3				0412/20033			
88	106	154	19	11,35	106	16	13,60	14,94	4,5	7,3	0410/28039						

4

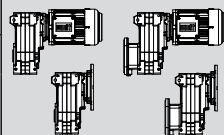
$P_N = 0,18 \text{ kW} / 0,25 \text{ HP}$

50 - 60 - 87 Hz 0,18 - 0,22 - 0,31 kW					60 Hz 0,18 kW			i	bei/at 50 Hz ($F_a=0$) ($F_r=0$)			m kg		ZT Code
n_{50} min ⁻¹	n_{60} min ⁻¹	n_{87} min ⁻¹	M_2 Nm	f_B	n_{60} min ⁻¹	M_2 Nm	f_B		F_{rN} kN	F_{aN} kN				
106	128	185	16	6,45	128	13	7,75	12,42	4,3	7,3	ASA 46S 64N4 ASA 46S IA63	18 15	260 546	0412/12041
118	142	205	15	7,10	142	12	8,50	11,19	4,1	7,2				0412/13040
136	163	237	13	8,10	163	11	9,70	9,70	3,9	6,8				0415/12032
157	188	273	11	9,35	188	9	11,20	8,41	3,7	6,5				0412/16037
187	224	325	9	10,90	224	8	13,05	7,07	3,5	6,2				0412/18035
220	264	383	8	11,65	264	7	14,00	6,00	3,4	5,9				0412/20033
261	313	454	7	12,45	313	5	14,95	5,07	3,2	5,5				0410/28039
313	375	544	5	13,30	375	5	15,95	4,22	3,0	5,2				0410/31036



4

P_N = 0,25 kW / 0,33 HP

50 - 60 - 87 Hz 0,25 - 0,30 - 0,43 kW					60 Hz 0,25 kW			i	bei/at 50 Hz (F _o =0) (F _r =0)			m kg		ZT Code
n ₅₀ min ⁻¹	n ₆₀ min ⁻¹	n ₈₇ min ⁻¹	M ₂ Nm	f _B	n ₆₀ min ⁻¹	M ₂ Nm	f _B		F _{rN} kN	F _{aN} kN				
1,0	1,2	1,8	2388	1,20	1,2	1990	1,45	850,50	24,7	36,8	ASA 86C 72N6	105	266	0507/10099
1,1	1,3	2,0	2170	1,30	1,3	1809	1,55	765,37	27,8	36,8	ASA 86C IA71	100	546	0507/11098
1,2	1,5	2,2	1990	1,45	1,5	1658	1,70	694,43	29,9	36,8	ARA 86C 72N6	135	486	0507/12097
1,4	1,6	2,4	1705	1,65	1,6	1421	2,00	634,41	32,6	36,8	ARA 86C IA71	130	546	0507/13096
1,4	1,7	2,4	1705	1,35	1,7	1421	1,65	954,55	32,6	36,8	ASA 86C 72K4	103	266	0507/09100
1,6	1,9	2,7	1492	1,90	1,9	1243	2,30	850,50	34,2	36,8	ASA 86C IA71	100	546	0507/10099
											ARA 86C 72K4	133	486	
											ARA 86C IA71	130	546	
					1,2	1820	0,85	1330,14	**	24,5	ASA 76D 72K4	65	270	0412/12041
1,1	1,3	1,9	1978	0,80	1,3	1648	0,95	1197,87	**	24,5	ASA 76D IA71	62	546	0412/13040
1,3	1,5	2,2	1663	0,95	1,5	1386	1,10	1038,16	9,0	24,5	ARA 76D 72K4	81	486	0415/12032
1,5	1,8	2,6	1435	1,05	1,8	1196	1,30	900,28	14,7	24,5	ARA 76D IA71	78	546	0412/16037
					1,3	1809	0,85	816,16	**	24,5	ASA 76C 72N6	64	266	0507/09100
1,2	1,4	2,1	1990	0,80	1,4	1658	0,95	727,20	**	24,5	ASA 76C IA71	58	546	0507/10099
1,3	1,6	2,3	1837	0,85	1,6	1530	1,00	654,41	**	24,5	ARA 76C 72N6	80	486	0507/11098
1,4	1,7	2,5	1705	0,90	1,7	1421	1,10	593,76	7,3	24,5	ARA 76C IA71	74	546	0507/12097
1,6	1,9	2,8	1492	1,05	1,9	1243	1,25	542,43	13,6	24,5				0507/13096
1,6	2,0	2,8	1492	1,05	2,0	1243	1,25	816,16	13,6	24,5				0507/09100
1,8	2,2	3,2	1326	1,15	2,2	1105	1,40	727,20	16,4	24,5	ASA 76C 72K4	62	266	0507/10099
2,0	2,4	3,5	1194	1,30	2,4	995	1,55	654,41	17,1	24,5	ASA 76C IA71	58	546	0507/11098
2,2	2,7	3,9	1085	1,40	2,7	904	1,70	593,76	17,7	24,5	ARA 76C 72K4	78	486	0507/12097
2,5	2,9	4,3	955	1,60	2,9	796	1,90	542,43	18,3	24,5	ARA 76C IA71	74	546	0507/13096
2,8	3,4	4,9	853	1,80	3,4	711	2,15	474,12	18,7	24,5				0510/11071
3,1	3,7	5,4	770	1,95	3,7	642	2,35	428,49	19,0	24,5				0510/12070
					2,5	947	0,85	643,52	**	20,3	ASA 66C 72K4			0407/10079
2,3	2,8	4,0	1038	0,80	2,8	865	0,95	577,61	**	20,3	ASA 66C IA71			0407/11078
2,5	3,1	4,4	955	0,85	3,1	796	1,05	522,69	**	20,3	ARA 66C 72K4			0407/12077
2,8	3,4	4,9	853	0,95	3,4	711	1,15	476,22	7,3	20,3	ARA 66C IA71			0407/13076
3,2	3,8	5,6	746	1,10	3,8	622	1,30	414,70	10,5	20,3		40	266	0410/11056
3,6	4,3	6,2	663	1,25	4,3	553	1,45	373,35	11,8	20,3		36	546	0410/12055
3,9	4,7	6,8	612	1,35	4,7	510	1,60	338,37	12,1	20,3		48	486	0410/13054
4,8	5,7	8,3	497	1,65	5,7	414	1,95	278,32	12,7	20,3		44	546	0412/12041
5,3	6,4	9,2	450	1,80	6,4	375	2,15	250,64	13,0	20,3				0412/13040
6,1	7,3	11	391	2,05	7,3	326	2,50	217,22	13,2	20,3				0415/12032
7,1	8,5	12	336	2,40	8,5	280	2,90	188,37	13,4	20,3				0412/16037
7,7	9,2	13	310	1,85	9,2	258	2,25	112,39	13,5	20,3	ASA 66A 72N6	40	262	0607/11129
8,4	10	15	284	2,70	10	237	3,25	102,22	13,5	20,3	ASA 66A IA71	34	546	0607/12128
9,2	11	16	260	3,10	11	216	3,70	93,62	13,6	20,3	ARA 66A 72N6	48	486	0607/13127
											ARA 66A IA71	42	546	
					4,8	497	0,85	333,90	4,2	11,6	ASA 56C 72K4			0407/12077
					5,2	452	0,90	304,21	6,5	11,6	ASA 56C IA71	25	266	0407/13076
5,0	6,0	8,7	478	0,85	6,0	398	1,05	264,91	8,4	11,6	ARA 56C 72K4	22	546	0410/11056
5,6	6,7	9,7	426	0,95	6,7	355	1,15	238,50	9,4	11,6	ARA 56C IA71	30	486	0410/12055
6,2	7,4	11	385	1,05	7,4	321	1,25	216,15	10,1	11,6		27	546	0410/13054
7,5	9,0	13	318	1,30	9,0	265	1,55	177,79	10,5	11,6				0412/12041
7,9	9,5	14	302	0,90	9,5	252	1,05	109,09	10,6	11,6	ASA 56A 72N6	25	260	0507/09100
8,8	11	15	271	1,35	11	226	1,60	97,20	10,7	11,6	ASA 56A IA71	20	546	0507/10099
9,8	12	17	244	1,65	12	203	2,00	87,47	10,8	11,6	ARA 56A 72N6	30	486	0507/11098
11	13	19	221	1,85	13	184	2,20	79,36	10,9	11,6	ARA 56A IA71	25	546	0507/12097
12	14	21	201	2,00	14	167	2,40	72,50	10,9	11,6				0507/13096

4

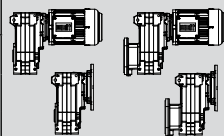
$P_N = 0,25 \text{ kW} / 0,33 \text{ HP}$

50 - 60 - 87 Hz 0,25 - 0,30 - 0,43 kW					60 Hz 0,25 kW			i	bei/at 50 Hz ($F_a=0$) ($F_r=0$)			m kg		ZT Code
n_{50} min ⁻¹	n_{60} min ⁻¹	n_{87} min ⁻¹	M_2 Nm	f_B	n_{60} min ⁻¹	M_2 Nm	f_B		F_{rN} kN	F_{aN} kN				
12	15	21	196	1,35	15	163	1,65	109,09	11,0	11,6	ASA 56A 72K4 ASA 56A IA71 ARA 56A 72K4 ARA 56A IA71	23	260	0507/09100
14	16	24	174	2,10	16	145	2,50	97,20	11,0	11,6		20	546	0507/10099
15	18	27	157	2,55	18	131	3,10	87,47	11,1	11,6		28	486	0507/11098
17	20	29	142	2,85	20	118	3,40	79,36	11,1	11,6		25	546	0507/12097
9,0	11	16	265	0,85	11	221	1,00	95,35	7,0	7,3	ASA 46A 72N6 ASA 46A IA71	20	260	0407/09080
10	12	18	236	0,95	12	197	1,15	84,75	7,2	7,3		15	546	0407/10079
11	14	20	211	1,05	14	176	1,25	76,07	7,4	7,3				0407/11078
13	15	22	191	1,20	15	159	1,40	68,83	7,5	7,3				0407/12077
14	17	24	172	1,30	17	143	1,55	95,35	7,6	7,3	ASA 46A 72K4 ASA 46A IA71	18	260	0407/09080
16	19	27	152	1,45	19	127	1,75	84,75	7,6	7,3				15
18	21	30	136	1,65	21	114	1,95	76,07	7,4	7,3				0407/11078
19	23	34	124	1,80	23	103	2,15	68,83	7,2	7,3				0407/12077
21	25	37	113	2,00	25	94	2,35	62,71	7,0	7,3				0407/13076
24	29	42	98	2,25	29	82	2,70	54,61	6,7	7,3				0410/11056
27	33	47	88	2,50	33	73	3,00	49,17	6,5	7,3				0410/12055
30	36	52	80	2,75	36	67	3,30	44,56	6,3	7,3				0410/13054
36	44	63	66	3,35	44	55	4,05	36,65	6,0	7,3				0412/12041
40	48	70	59	3,75	48	49	4,50	33,01	5,8	7,3				0412/13040
47	56	81	51	4,30	56	43	5,15	28,61	5,5	7,3				0415/12032
54	64	93	45	4,95	64	37	5,95	24,81	5,3	7,3				0412/16037
64	77	111	37	5,90	77	31	7,10	20,86	5,0	7,3				0412/18035
75	90	131	32	6,95	90	26	8,35	17,70	4,7	7,3				0412/20033
89	107	155	27	8,25	107	22	9,85	14,94	4,5	7,3				0410/28039
107	129	186	22	4,70	129	19	5,60	12,42	4,2	7,3		ASA 46S 72K4 ASA 46S IA71	18	260
119	143	207	20	5,15	143	17	6,20	11,19	4,1	7,1	15			
137	165	239	17	5,90	165	15	7,05	9,70	3,9	6,8				0415/12032
158	190	275	15	6,80	190	13	8,15	8,41	3,7	6,5				0412/16037
188	226	327	13	7,90	226	11	9,50	7,07	3,5	6,1				0412/18035
222	266	386	11	8,50	266	9	10,15	6,00	3,3	5,8				0412/20033
263	315	457	9	9,05	315	8	10,85	5,07	3,2	5,5				0410/28039
315	378	548	8	9,65	378	6	11,60	4,22	3,0	5,2				0410/31036

4



$P_N = 0,37 \text{ kW} / 0,50 \text{ HP}$

50 - 60 - 87 Hz (100 Hz) ¹⁾ 0,37 - 0,44 - 0,64 kW (0,74 kW)					60 Hz 0,37 kW			i	bei/at 50 Hz (F _o =0) (F _r =0)			m kg		ZT Code	
n ₅₀ min ⁻¹	n ₆₀ min ⁻¹	n ₈₇ min ⁻¹	M ₂ Nm	f _B	n ₆₀ min ⁻¹	M ₂ Nm	f _B		F _{rN} kN	F _{aN} kN					
1,0	1,1	1,7	3109	1,65	1,1	2591	1,95	1397,17	40,8	46,5	FSA 111D 72N4 FSA 111D IA71 FRA 111D 72N4 FRA 111D IA71	208	272	0515/12042	
1,1	1,3	1,9	2809	1,80	1,3	2341	2,15	1222,52	43,4	46,5		204	546	0512/16049	
												269	486		
												265	546		
1,1	1,3	2,1	3212	0,90	1,3	2677	1,05	850,50	**	36,8	ASA 86C 81K6 ASA 86C IA80 ARA 86C 81K6 ARA 86C IA80	106	266	0507/10099	
1,2	1,4	2,4	2945	1,00	1,4	2454	1,15	765,37	11,6	36,8		100	546	0507/11098	
1,3	1,6	2,6	2718	1,05	1,6	2265	1,25	694,43	18,5	36,8		136	486	0507/12097	
												130	546		
1,4	1,7	2,4	2524	0,95	1,7	2103	1,10	954,55	22,5	36,8	ASA 86C 72N4 ASA 86C IA71 ARA 86C 72N4 ARA 86C IA71	104	266	0507/09100	
1,6	1,9	2,7	2208	1,30	1,9	1840	1,55	850,50	27,3	36,8		100	546	0507/10099	
1,7	2,1	3,0	2079	1,35	2,1	1732	1,65	765,37	28,9	36,8		134	486	0507/12097	
1,9	2,3	3,3	1860	1,55	2,3	1550	1,85	694,43	31,2	36,8		130	546	0507/13096	
2,1	2,5	3,6	1683	1,70	2,5	1402	2,00	634,41	32,8	36,8				0510/11071	
2,4	2,9	4,2	1472	1,95	2,9	1227	2,30	554,50	34,3	36,8					
					2,0	1840	0,85	816,16	**	24,5					0507/09100
1,8	2,2	3,2	1963	0,80	2,2	1636	0,95	727,20	**	24,5	ASA 76C 72N4 ASA 76C IA71 ARA 76C 72N4 ARA 76C IA71	63	266	0507/10099	
2,0	2,4	3,5	1767	0,85	2,4	1472	1,05	654,41	3,5	24,5		58	546	0507/11098	
2,2	2,7	3,9	1606	0,95	2,7	1338	1,15	593,76	10,8	24,5		79	486	0507/12097	
2,5	2,9	4,3	1413	1,10	2,9	1178	1,30	542,43	15,1	24,5		74	546	0507/13096	
2,8	3,4	4,9	1262	1,20	3,4	1052	1,45	474,12	16,8	24,5				0510/11071	
3,1	3,7	5,4	1140	1,35	3,7	950	1,60	428,49	17,4	24,5				0510/12070	
3,4	4,1	5,9	1039	1,45	4,1	866	1,75	389,87	17,9	24,5				0510/13069	
4,1	4,9	7,1	862	1,75	4,9	718	2,10	324,42	18,6	24,5				0512/12053	
4,5	5,4	7,9	785	1,95	5,4	654	2,30	293,82	18,9	24,5				0512/13052	
					3,4	1052	0,80	476,22	**	20,3		ASA 66C 72N4 ASA 66C IA71 ARA 66C 72N4 ARA 66C IA71	41	266	0407/13076
					3,8	920	0,90	414,70	**	20,3			36	546	0410/11056
3,6	4,3	6,2	982	0,85	4,3	818	1,00	373,35	**	20,3	49		486	0410/12055	
3,9	4,7	6,8	906	0,90	4,7	755	1,10	338,37	4,8	20,3	44		546	0410/13054	
4,8	5,7	8,3	736	1,10	5,7	613	1,35	278,32	10,7	20,3				0412/12041	
5,3	6,4	9,2	667	1,20	6,4	556	1,45	250,64	11,8	20,3				0412/13040	
6,1	7,3	11	579	1,40	7,3	483	1,70	217,22	12,3	20,3				0415/12032	
7,1	8,5	12	498	1,65	8,5	415	1,95	188,37	12,7	20,3				0412/16037	
8,0	9,6	16	442	1,30	9,6	368	1,60	112,39	13,0	20,3	ASA 66A 81K6 ASA 66A IA80 ARA 66A 81K6 ARA 66A IA80	40	262	0607/11129	
8,8	11	18	402	1,95	11	335	2,30	102,22	13,2	20,3		35	546	0607/12128	
9,6	12	19	368	2,20	12	307	2,65	93,62	13,3	20,3		48	486	0607/13127	
11	13	22	321	2,50	13	268	3,00	81,89	13,4	20,3		43	546	0610/11094	
12	14	21	299	1,95	14	250	2,30	112,39	13,5	20,3	ASA 66A 72N4 ASA 66A IA71 ARA 66A 72N4 ARA 66A IA71	38	262	0607/11129	
13	16	23	272	2,85	16	227	3,40	102,22	13,6	20,3		34	546	0607/12128	
												46	486		
												42	546		
					6,7	526	0,80	238,50	0,8	11,6	ASA 56C 72N4 ASA 56C IA71 ARA 56C 72N4 ARA 56C IA71	26	266	0410/12055	
					7,4	475	0,85	216,15	5,5	11,6		22	546	0410/13054	
7,5	9,0	13	471	0,85	9,0	393	1,05	177,79	8,5	11,6		31	486	0412/12041	
8,3	10	15	426	0,95	10	355	1,15	160,11	9,4	11,6		27	546	0412/13040	
9,6	12	17	368	1,10	12	307	1,35	138,76	10,2	11,6				0415/12032	
9,3	11	19	380	0,95	11	317	1,15	97,20	10,1	11,6	ASA 56A 81K6 ASA 56A IA80 ARA 56A 81K6 ARA 56A IA80	26	260	0507/10099	
10	12	21	343	1,20	12	286	1,40	87,47	10,4	11,6		20	546	0507/11098	
11	14	23	313	1,30	14	261	1,55	79,36	10,5	11,6		31	486	0507/12097	
												25	546		
12	15	21	290	0,95	15	241	1,10	109,09	10,6	11,6	ASA 56A 72N4 ASA 56A IA71 ARA 56A 72N4 ARA 56A IA71	24	260	0507/09100	
14	16	24	258	1,40	16	215	1,70	97,20	10,7	11,6				0507/10099	
15	18	27	232	1,75	18	194	2,10	87,47	10,8	11,6				0507/11098	
17	20	29	210	1,95	20	175	2,30	79,36	10,9	11,6				0507/12097	
18	22	32	193	2,10	22	161	2,50	72,50	11,0	11,6				0507/13096	
21	25	37	168	2,40	25	140	2,90	63,37	11,0	11,6				0510/11071	
23	28	40	152	2,65	28	127	3,20	57,27	11,1	11,6				0510/12070	
26	31	44	139	2,90	31	115	3,50	52,11	11,1	11,6				0510/13069	

¹⁾ 100 Hz Kennlinie bei Motortype 81.
¹⁾ 100 Hz characteristic for motor type 81.

** ... auf Anfrage
** ... on request

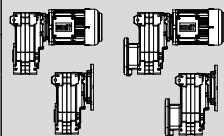
$P_N = 0,37 \text{ kW} / 0,50 \text{ HP}$



50 - 60 - 87 Hz (100 Hz) ¹⁾ 0,37 - 0,44 - 0,64 kW (0,74 kW)					60 Hz 0,37 kW			i	bei/at 50 Hz (F _a =0) (F _r =0)			m kg		ZT Code
n ₅₀ min ⁻¹	n ₆₀ min ⁻¹	n ₈₇ min ⁻¹	M ₂ Nm	f _B	n ₆₀ min ⁻¹	M ₂ Nm	f _B		F _{rN} kN	F _{aN} kN				
					13	278	0,80	84,75	5,3	7,3	ASA 46A 81K6 ASA 46A IA80	22 16	260 546	0407/10079 0407/11078 0407/12077
					14	250	0,90	76,07	6,3	7,3				
13	16	26	270	0,85	16	225	1,00	68,83	6,9	7,3				
14	17	24	254	0,90	17	212	1,05	95,35	7,1	7,3	ASA 46A 72N4 ASA 46A IA71	20 15	260 546	0407/09080 0407/10079 0407/11078 0407/12077 0407/13076 0410/11056 0410/12055 0410/13054 0412/12041 0412/13040 0415/12032 0412/16037 0412/18035 0412/20033 0410/28039
16	19	27	225	1,00	19	188	1,20	84,75	7,3	7,3				
18	21	30	202	1,10	21	168	1,35	76,07	7,2	7,3				
19	23	34	183	1,25	23	153	1,45	68,83	7,0	7,3				
21	25	37	167	1,35	25	139	1,60	62,71	6,8	7,3				
24	29	42	145	1,55	29	121	1,85	54,61	6,6	7,3				
27	33	47	130	1,70	33	109	2,05	49,17	6,4	7,3				
30	36	52	119	1,90	36	99	2,25	44,56	6,2	7,3				
36	44	63	97	2,30	44	81	2,75	36,65	5,8	7,3				
40	48	70	88	2,55	48	73	3,05	33,01	5,7	7,3				
47	56	81	76	2,90	56	63	3,50	28,61	5,4	7,3				
54	64	93	66	3,35	64	55	4,05	24,81	5,2	7,3				
64	77	111	55	4,00	77	46	4,80	20,86	4,9	7,3				
75	90	131	47	4,70	90	39	5,65	17,70	4,7	7,3				
89	107	155	40	5,55	107	33	6,65	14,94	4,4	7,3				
107	129	186	33	3,15	129	28	3,80	12,42	4,2	7,3	ASA 46S 72N4 ASA 46S IA71	20 15	260 546	0412/12041 0412/13040 0415/12032 0412/16037 0412/18035 0412/20033 0410/28039 0410/31036
119	143	207	30	3,50	143	25	4,20	11,19	4,0	7,0				
137	165	239	26	4,00	165	21	4,80	9,70	3,9	6,7				
158	190	275	22	4,60	190	19	5,50	8,41	3,7	6,4				
188	226	327	19	5,35	226	16	6,40	7,07	3,5	6,1				
222	266	386	16	5,75	266	13	6,90	6,00	3,3	5,8				
263	315	457	13	6,10	315	11	7,35	5,07	3,1	5,5				
315	378	548	11	6,55	378	9	7,85	4,22	3,0	5,2				

P_N = 0,55 kW / 0,75 HP

50 - 60 - 100 Hz 0,55 - 0,66 - 1,1 kW					60 Hz 0,55 kW			i	bei/at 50 Hz (F ₀ =0) (F _r =0)			m kg		ZT Code				
n ₅₀ min ⁻¹	n ₆₀ min ⁻¹	n ₁₀₀ min ⁻¹	M ₂ Nm	f _B	n ₆₀ min ⁻¹	M ₂ Nm	f _B		F _{rN} kN	F _{aN} kN								
1,0	1,2	2,0	4602	1,75	1,2	3835	2,10	1328,73	68,1	66,0	FSA 131D 81K4 FSA 131D IA80 FRA 131D 81K4 FRA 131D IA80	318	272	0515/12042				
1,1	1,4	2,3	4149	1,95	1,4	3458	2,35	1162,64	68,9	66,0		312	546	0512/16049				
1,3	1,6	2,7	3453	2,35	1,6	2878	2,80	991,27	70,0	66,0		398	486	0512/18047				
											FSA 111D 81K4 FSA 111D IA80 FRA 111D 81K4 FRA 111D IA80							
1,1	1,3	2,2	4280	1,20	1,3	3567	1,45	1222,52	24,5	46,5		211	272	0512/16049				
1,3	1,5	2,5	3592	1,40	1,5	2993	1,70	1042,33	35,5	46,5		204	546	0512/18047				
1,5	1,8	2,9	3081	1,65	1,8	2567	1,95	898,18	41,0	46,5	272	486	0512/20045					
											FSA 111C 81N6 FSA 111C IA80 FRA 111C 81N6 FRA 111C IA80							
1,7	2,0	3,4	3090	1,65	2,0	2575	1,95	530,74	40,9	46,5		207	268	0710/11117				
1,9	2,2	3,7	2764	1,85	2,2	2304	2,20	482,36	43,7	46,5		200	546	0710/12116				
2,0	2,4	4,1	2626	1,95	2,4	2189	2,30	441,41	44,7	46,5	268	486	0710/13115					
											ASA 86C 81K4 ASA 86C IA80 ARA 86C 81K4 ARA 86C IA80							
1,6	1,9	3,1	3283	0,90	1,9	2736	1,05	850,50	**	36,8		107	266	0507/10099				
1,7	2,1	3,4	3090	0,95	2,1	2575	1,10	765,37	**	36,8				0507/11098				
1,9	2,3	3,8	2764	1,05	2,3	2304	1,25	694,43	17,3	36,8	0507/12097							
2,1	2,5	4,2	2501	1,15	2,5	2084	1,35	634,41	22,9	36,8	0507/13096							
2,4	2,9	4,8	2189	1,30	2,9	1824	1,55	554,50	27,5	36,8	0510/11071							
2,6	3,2	5,3	2020	1,40	3,2	1683	1,70	501,14	29,5	36,8	0510/12070							
2,9	3,5	5,8	1811	1,55	3,5	1509	1,90	455,98	31,6	36,8	0510/13069							
3,5	4,2	7,0	1501	1,90	4,2	1251	2,25	379,43	34,1	36,8	0512/12053							
3,8	4,6	7,7	1382	2,05	4,6	1152	2,45	343,64	34,9	36,8	0512/13052							
4,4	5,3	8,8	1194	2,35	5,3	995	2,85	300,68	35,6	36,8	0515/12042							
5,0	6,0	10	1051	2,70	6,0	875	3,20	263,10	35,9	36,8	0512/16049							
5,9	7,1	12	890	3,15	7,1	742	3,80	224,32	36,2	36,8	0512/18047							
											66			266				
					2,7	1990	0,80	593,76	**	24,5					0507/12097			
					2,9	1824	0,85	542,43	**	24,5					0507/13096			
2,8	3,3	5,6	1876	0,80	3,3	1563	1,00	474,12	**	24,5		0510/11071						
3,1	3,7	6,2	1694	0,90	3,7	1412	1,10	428,49	7,8	24,5		0510/12070						
3,4	4,1	6,8	1545	1,00	4,1	1287	1,20	389,87	12,4	24,5		0510/13069						
4,1	4,9	8,1	1281	1,20	4,9	1068	1,45	324,42	16,6	24,5		0512/12053						
4,5	5,4	9,0	1167	1,30	5,4	973	1,55	293,82	17,3	24,5		0512/13052						
5,1	6,2	10	1030	1,50	6,2	858	1,75	257,09	18,0	24,5		0515/12042						
5,9	7,0	12	890	1,70	7,0	742	2,05	224,96	18,5	24,5		0512/16049						
6,9	8,3	14	761	2,00	8,3	634	2,40	191,80	19,0	24,5		0512/18047						
8,0	9,6	16	657	2,30	9,6	547	2,75	165,27	19,3	24,5		0512/20045						
												ASA 76A 81N6 ASA 76A IA80 ARA 76A 81N6 ARA 76A IA80						
9,2	11	18	571	2,30	11	476	2,75	97,66	19,5	24,5			65		262	0710/11117		
10	12	20	520	2,90	12	433	3,50	88,76	19,6	24,5			58		546	0710/12116		
											81	486						
													74	546				
											44	266						
5,3	6,3	11	991	0,85	5,7	931	0,90	278,32	**	20,3			0412/12041					
6,1	7,3	12	861	0,95	6,3	826	1,00	250,64	**	20,3			0412/13040					
7,0	8,4	14	750	1,10	7,3	718	1,15	217,22	7,0	20,3			0415/12032					
8,3	10	17	633	1,30	8,4	625	1,30	188,37	10,4	20,3			0412/16037					
8,0	9,6	16	657	0,90	10	527	1,55	158,39	12,0	20,3			0412/18035					
8,8	11	18	597	1,30	11	497	1,55	102,22	12,2	20,3			ASA 66A 81N6 ASA 66A IA80 ARA 66A 81N6 ARA 66A IA80	42	262	0607/11129		
9,6	12	19	547	1,50	12	456	1,80	93,62	12,5	20,3				35	546	0607/12128		
11	13	22	478	1,70	13	398	2,05	81,89	12,8	20,3				50	486	0607/13127		
													43	546	0610/11094			
12	14	24	449	1,30	14	374	1,55	112,39	13,0	20,3					ASA 66A 81K4 ASA 66A IA80 ARA 66A 81K4 ARA 66A IA80	42	262	0607/11129
13	16	26	407	1,90	16	339	2,25	102,22	13,1	20,3						35	546	0607/12128
14	17	28	373	2,15	17	310	2,60	93,62	13,3	20,3						50	486	0607/13127
16	19	32	326	2,50	19	272	2,95	81,89	13,4	20,3						43	546	0610/11094
18	21	36	295	2,75	21	246	3,30	74,27	13,5	20,3						43	546	0610/12093

4

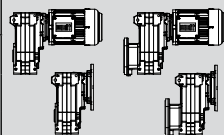
$P_N = 0,55 \text{ kW} / 0,75 \text{ HP}$

50 - 60 - 100 Hz 0,55 - 0,66 - 1,1 kW					60 Hz 0,55 kW			i	bei/at 50 Hz ($F_a=0$) ($F_r=0$)			m kg		ZT Code
n_{50} min ⁻¹	n_{60} min ⁻¹	n_{100} min ⁻¹	M_2 Nm	f_B	n_{60} min ⁻¹	M_2 Nm	f_B		F_{rN} kN	F_{aN} kN				
					11	471	0,80	97,20	5,7	11,6	ASA 56A 81N6 ASA 56A IA80 ARA 56A 81N6 ARA 56A IA80	28	260	0507/10099
10	12	21	510	0,80	12	425	0,95	87,47	7,5	11,6		20	546	0507/11098
11	14	23	465	0,90	14	387	1,05	79,36	8,6	11,6		33	486	0507/12097
12	15	25	424	0,95	15	353	1,15	72,50	9,5	11,6		25	546	0507/13096
14	16	27	386	0,95	16	322	1,15	97,20	10,1	11,6	ASA 56A 81K4 ASA 56A IA80 ARA 56A 81K4 ARA 56A IA80			0507/10099
15	18	30	348	1,15	18	290	1,40	87,47	10,3	11,6				0507/11098
17	20	33	316	1,30	20	264	1,55	79,36	10,5	11,6				0507/12097
18	22	36	289	1,40	22	240	1,70	72,50	10,6	11,6				0507/13096
21	25	42	253	1,60	25	210	1,95	63,37	10,8	11,6				0510/11071
23	28	46	228	1,80	28	190	2,15	57,27	10,9	11,6		27	260	0510/12070
25	30	51	208	1,95	30	173	2,35	52,11	10,9	11,6		20	546	0510/13069
30	37	61	173	2,35	37	144	2,80	43,36	10,7	11,6		32	486	0512/12053
34	40	67	156	2,60	40	130	3,10	39,27	10,4	11,6		25	546	0512/13052
					19	281	0,80	84,75	5,2	7,3		ASA 46A 81K4 ASA 46A IA80		
					21	252	0,90	76,07	6,2	7,3				0407/11078
19	23	38	274	0,85	23	228	1,00	68,83	6,7	7,3				0407/12077
21	25	42	250	0,90	25	208	1,10	62,71	6,5	7,3				0407/13076
24	29	48	217	1,05	29	181	1,25	54,61	6,3	7,3				0410/11056
27	32	54	196	1,15	32	163	1,35	49,17	6,1	7,3				0410/12055
30	36	59	177	1,25	36	148	1,50	44,56	6,0	7,3				0410/13054
36	43	72	146	1,55	43	122	1,85	36,65	5,7	7,3	22		260	0410/13054
40	48	80	131	1,70	48	109	2,05	33,01	5,5	7,3	16		546	0412/12041
46	55	92	114	1,95	55	95	2,35	28,61	5,3	7,3				0412/13040
53	64	106	99	2,25	64	82	2,70	24,81	5,1	7,3				0415/12032
63	76	127	83	2,70	76	69	3,20	20,86	4,8	7,3				0412/16037
75	90	149	70	3,15	90	59	3,75	17,70	4,6	7,3				0412/18035
88	106	177	59	3,70	106	50	4,45	14,94	4,4	7,3				0412/20033
													0410/28039	
106	128	213	49	2,15	128	41	2,55	12,42	4,1	7,1	ASA 46S 81K4 ASA 46S IA80			0412/12041
118	142	236	45	2,35	142	37	2,80	11,19	4,0	6,9				0412/13040
136	163	272	39	2,65	163	32	3,20	9,70	3,8	6,6				0415/12032
157	188	314	33	3,05	188	28	3,70	8,41	3,7	6,3				0412/16037
187	224	373	28	3,60	224	23	4,30	7,07	3,5	6,0		22	260	0412/16037
220	264	440	24	3,85	264	20	4,60	6,00	3,3	5,7		16	546	0412/18035
261	313	521	20	4,10	313	17	4,90	5,07	3,1	5,4				0412/20033
313	375	625	17	4,35	375	14	5,25	4,22	2,9	5,1				0410/28039
														0410/31036



P_N = 0,75 kW / 1,0 HP

50 - 60 - 100 Hz 0,75 - 0,90 - 1,5 kW					60 Hz 0,75 kW			i	bei/at 50 Hz (F _a =0) (F _r =0)			m kg		ZT Code
n ₅₀ min ⁻¹	n ₆₀ min ⁻¹	n ₁₀₀ min ⁻¹	M ₂ Nm	f _B	n ₆₀ min ⁻¹	M ₂ Nm	f _B		F _{rN} kN	F _{aN} kN				
1,1	1,3	2,1	5788	1,40	1,3	4824	1,70	1328,73	65,6	66,0	FSA 131D 70 81N4	321	272	0515/12042
1,2	1,5	2,4	5273	1,55	1,5	4394	1,85	1162,64	66,8	66,0	FSA 131D IA80	312	546	0512/16049
1,4	1,7	2,8	4473	1,80	1,7	3728	2,15	991,27	68,4	66,0	FRA 131D 70 81N4	401	486	0512/18047
											FRA 131D IA80	392	546	
1,0	1,2	2,0	6526	0,80	1,2	5438	0,95	1397,17	**	46,5	FSA 111D 70 81N4	214	272	0515/12042
1,2	1,4	2,3	5405	0,95	1,4	4504	1,15	1222,52	**	46,5	FSA 111D IA80	204	546	0512/16049
1,4	1,6	2,7	4604	1,10	1,6	3837	1,35	1042,33	15,6	46,5	FRA 111D 70 81N4	275	486	0512/18047
1,6	1,9	3,1	4004	1,25	1,9	3337	1,50	898,18	29,6	46,5	FRA 111D IA80	265	546	0512/20045
1,8	2,1	3,6	3979	1,30	2,1	3316	1,55	530,74	30,1	46,5	FSA 111C 70 91S6	211	268	0710/11117
2,0	2,4	3,9	3581	1,40	2,4	2984	1,70	482,36	35,7	46,5	FSA 111C IA90	200	546	0710/12116
2,1	2,6	4,3	3411	1,50	2,6	2842	1,80	441,41	37,7	46,5	FRA 111C 70 91S6	272	486	0710/13115
2,5	3,0	5,0	2865	1,75	3,0	2388	2,10	378,40	42,9	46,5	FRA 111C IA90	261	546	0712/12091
2,7	3,2	5,3	2653	1,90	3,2	2211	2,30	530,74	44,5	46,5	FSA 111C 70 81N4	209	268	0710/11117
2,9	3,5	5,8	2470	2,05	3,5	2058	2,45	482,36	45,8	46,5	FSA 111C IA80	200	546	0710/12116
											FRA 111C 70 81N4	270	486	
											FRA 111C IA80	261	546	
					2,0	3511	0,80	850,50	**	36,8				0507/10099
					2,2	3316	0,85	765,37	**	36,8				0507/11098
2,0	2,4	4,1	3581	0,80	2,4	2984	0,95	694,43	**	36,8				0507/12097
2,2	2,7	4,4	3256	0,90	2,7	2713	1,05	634,41	**	36,8				0507/13096
2,5	3,1	5,1	2865	1,00	3,1	2388	1,20	554,50	14,5	36,8				0510/11071
2,8	3,4	5,6	2558	1,10	3,4	2132	1,35	501,14	21,8	36,8	ASA 86C 70 81N4	110	266	0510/12070
3,1	3,7	6,2	2310	1,25	3,7	1925	1,50	455,98	25,9	36,8	ASA 86C IA80	100	546	0510/13069
3,7	4,5	7,4	1936	1,45	4,5	1613	1,75	379,43	30,4	36,8	ARA 86C 70 81N4	140	486	0512/12053
4,1	4,9	8,2	1747	1,65	4,9	1456	1,95	343,64	32,2	36,8	ARA 86C IA80	130	546	0512/13052
4,7	5,6	9,4	1524	1,85	5,6	1270	2,25	300,68	34,0	36,8				0515/12042
5,4	6,4	11	1326	2,15	6,4	1105	2,55	263,10	35,3	36,8				0512/16049
6,3	7,5	13	1137	2,50	7,5	947	3,00	224,32	35,7	36,8				0512/18047
7,3	8,8	15	981	2,90	8,8	818	3,45	193,30	36,0	36,8				0512/20045
8,5	10	17	843	3,35	10	702	4,00	165,68	36,2	36,8				0510/28054
					3,6	1990	0,80	474,12	**	24,5				0510/11071
					3,9	1809	0,85	428,49	**	24,5				0510/12070
3,6	4,3	7,2	1990	0,80	4,3	1658	0,95	389,87	**	24,5				0510/13069
4,3	5,2	8,7	1666	0,95	5,2	1388	1,10	324,42	8,9	24,5	ASA 76C 70 81N4	69	266	0512/12053
4,8	5,8	9,6	1492	1,05	5,8	1243	1,25	293,82	13,6	24,5	ASA 76C IA80	60	546	0512/13052
5,5	6,6	11	1302	1,20	6,6	1085	1,40	257,09	16,5	24,5	ARA 76C 70 81N4	85	486	0515/12042
6,3	7,5	13	1137	1,35	7,5	947	1,60	224,96	17,4	24,5	ARA 76C IA80	76	546	0512/16049
7,4	8,8	15	968	1,55	8,8	807	1,90	191,80	18,2	24,5				0512/18047
8,5	10	17	843	1,80	10	702	2,15	165,27	18,7	24,5				0512/20045
9,7	12	19	738	1,75	12	615	2,10	97,66	19,1	24,5	ASA 76A 70 91S6	69	262	0710/11117
11	13	21	676	2,25	13	563	2,70	88,76	19,2	24,5	ASA 76A IA90	58	546	0710/12116
12	14	23	617	2,45	14	515	2,95	81,224	19,4	24,5	ARA 76A 70 91S6	85	486	0710/13115
14	16	27	527	2,85	16	439	3,45	69,629	19,6	24,5	ARA 76A IA90	74	546	0712/12091
14	17	29	497	2,60	17	414	3,15	97,66	19,7	24,5	ASA 76A 70 81N4	67	262	0710/11117
16	19	32	450	3,35	19	375	4,00	88,76	19,8	24,5	ASA 76A IA80	58	546	0710/12116
											ARA 76A 70 81N4	83	486	
											ARA 76A IA80	74	546	
					6,8	1066	0,80	250,64	**	20,3	ASA 66C 70 81N4	47	266	0412/13040
					7,8	918	0,90	217,22	**	20,3	ASA 66C IA80	38	546	0415/12032
7,5	9,0	15	955	0,85	9,0	796	1,05	188,37	**	20,3	ARA 66C 70 81N4	55	486	0412/16037
											ARA 66C IA80	46	546	
					10	711	0,85	112,39	7,3	20,3	ASA 66A 70 91S6	46	266	0607/11129
9,2	11	19	779	1,00	11	649	1,20	102,22	9,7	20,3	ASA 66A IA90	35	546	0607/12128
10	12	20	709	1,15	12	591	1,40	93,62	11,3	20,3	ARA 66A 70 91S6	54	486	0607/13127
12	14	23	623	1,30	14	519	1,55	81,89	12,0	20,3	ARA 66A IA90	43	546	0610/11094

4

** ... auf Anfrage
** ... on request

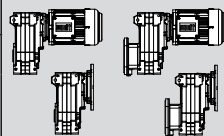
P_N = 0,75 kW / 1,0 HP



50 - 60 - 100 Hz 0,75 - 0,90 - 1,5 kW					60 Hz 0,75 kW			i	bei/at 50 Hz (F _a =0) (F _r =0)			m kg		ZT Code
n ₅₀ min ⁻¹	n ₆₀ min ⁻¹	n ₁₀₀ min ⁻¹	M ₂ Nm	f _B	n ₆₀ min ⁻¹	M ₂ Nm	f _B		F _{rN} kN	F _{aN} kN				
13	15	25	573	1,05	15	478	1,25	112,39	12,3	20,3	ASA 66A 70 81N4 ASA 66A IA80 ARA 66A 70 81N4 ARA 66A IA80	44	262	0607/11129
14	17	28	519	1,50	17	433	1,80	102,22	12,6	20,3		35	546	0607/12128
15	18	30	474	1,70	18	395	2,05	93,62	12,9	20,3		52	486	0607/13127
17	21	34	416	1,95	21	347	2,35	81,89	13,1	20,3		43	546	0610/11094
19	23	38	377	2,15	23	314	2,55	74,27	13,2	20,3				0610/12093
21	25	42	344	2,35	25	287	2,80	67,82	13,4	20,3				0610/13092
25	29	49	292	2,75	29	244	3,30	57,50	13,5	20,3			0612/12072	
					17	412	0,90	97,20	8,0	11,6	ASA 56A 70 81N4 ASA 56A IA80 ARA 56A 70 81N4 ARA 56A IA80			0507/10099
16	19	32	445	0,90	19	371	1,10	87,47	9,1	11,6				0507/11098
18	21	36	402	1,00	21	335	1,20	79,36	9,8	11,6				0507/12097
19	23	39	369	1,10	23	308	1,35	72,50	10,2	11,6				0507/13096
22	27	45	323	1,25	27	269	1,50	63,37	10,5	11,6		30	260	0510/11071
25	30	49	291	1,40	30	243	1,65	57,27	10,6	11,6		20	546	0510/12070
27	33	54	264	1,55	33	220	1,85	52,11	10,7	11,6		35	486	0510/13069
33	39	65	220	1,85	39	184	2,20	43,36	10,3	11,6		25	546	0512/12053
36	43	72	200	2,05	43	166	2,45	39,27	10,0	11,6				0512/13052
41	49	82	175	2,30	49	146	2,75	34,36	9,6	11,6				0515/12042
47	56	94	153	2,65	56	127	3,15	30,07	9,2	11,6				0512/16049
55	66	110	130	3,10	66	109	3,70	25,64	8,8	11,6				0512/18047
					25	291	0,80	68,83	4,8	7,3	ASA 46A 70 81N4 ASA 46A IA80			0407/12077
					27	265	0,85	62,71	5,8	7,3				0407/13076
26	31	52	278	0,80	31	231	1,00	54,61	5,9	7,3				0410/11056
29	34	57	250	0,90	34	208	1,10	49,17	5,8	7,3				0410/12055
32	38	63	227	1,00	38	189	1,20	44,56	5,7	7,3				0410/13054
39	46	77	186	1,20	46	155	1,45	36,65	5,4	7,3		26	260	0412/12041
43	51	85	168	1,35	51	140	1,60	33,01	5,3	7,3		16	546	0412/13040
49	59	99	145	1,55	59	121	1,85	28,61	5,1	7,3				0415/12032
57	68	114	126	1,75	68	105	2,10	24,81	4,9	7,3				0412/16037
68	81	135	106	2,10	81	88	2,50	20,86	4,7	7,3				0412/18035
80	96	159	90	2,45	96	75	2,95	17,70	4,4	7,3			0412/20033	
94	113	189	76	2,90	113	63	3,50	14,94	4,2	7,3			0410/28039	
114	136	227	63	1,65	136	53	2,00	12,42	4,0	6,9	ASA 46S 70 81N4 ASA 46S IA80			0412/12041
126	151	252	57	1,85	151	47	2,20	11,19	3,9	6,7				0412/13040
145	175	291	49	2,10	175	41	2,50	9,70	3,7	6,4				0415/12032
168	201	335	43	2,40	201	36	2,90	8,41	3,5	6,1		26	260	0412/16037
199	239	399	36	2,80	239	30	3,35	7,07	3,4	5,8		16	546	0412/18035
235	282	470	30	3,00	282	25	3,60	6,00	3,2	5,5				0412/20033
278	334	557	26	3,20	334	21	3,85	5,07	3,0	5,3				0410/28039
334	401	668	21	3,45	401	18	4,10	4,22	2,9	5,0			0410/31036	

P_N = 1,1 kW / 1,5 HP

50 - 60 - 100 Hz 1,1 - 1,3 - 2,2 kW					60 Hz 1,1 kW			i	bei/at 50 Hz (F _o =0) (F _r =0)			m kg		ZT Code	
n ₅₀ min ⁻¹	n ₆₀ min ⁻¹	n ₁₀₀ min ⁻¹	M ₂ Nm	f _B	n ₆₀ min ⁻¹	M ₂ Nm	f _B		F _{rN} kN	F _{aN} kN					
1,1	1,3	2,1	8648	0,95	1,3	7207	1,15	1328,73	38,7	66,0	FSA 131D 70 91S4 FSA 131D IA90 FRA 131D 70 91S4 FRA 131D IA90	325	272	0515/12042	
1,2	1,5	2,4	7895	1,05	1,5	6579	1,25	1162,64	49,7	66,0		312	546	0512/16049	
1,4	1,7	2,9	6725	1,20	1,7	5605	1,45	991,27	61,8	66,0		405	486	0512/18047	
1,7	2,0	3,3	5471	1,50	2,0	4559	1,80	854,18	66,4	66,0		392	546	0512/20045	
1,9	2,3	3,9	4865	1,65	2,3	4054	2,00	732,16	67,6	66,0				0510/28054	
2,3	2,7	4,5	3953	2,05	2,7	3294	2,45	624,56	69,2	66,0			0510/31051		
1,8	2,1	3,6	5836	0,90	2,1	4863	1,05	530,74	**	46,5	FSA 111C 70 91L6 FSA 111C IA90 FRA 111C 70 91L6 FRA 111C IA90	216	268	0710/11117	
2,0	2,4	3,9	5253	1,00	2,4	4377	1,15	482,36	**	46,5		200	546	0710/12116	
2,1	2,6	4,3	5002	1,00	2,6	4169	1,20	441,41	**	46,5		277	486	0710/13115	
2,5	3,0	5,0	4202	1,20	3,0	3502	1,45	378,40	26,1	46,5		261	546	0712/12091	
2,7	3,2	5,4	3891	1,30	3,2	3242	1,55	530,74	31,4	46,5				0710/11117	
2,9	3,5	5,9	3622	1,40	3,5	3019	1,70	482,36	35,2	46,5	FSA 111C 70 91S4 FSA 111C IA90 FRA 111C 70 91S4 FRA 111C IA90	213	268	0710/12116	
3,2	3,9	6,4	3283	1,55	3,9	2736	1,85	441,41	39,0	46,5		200	546	0710/13115	
3,8	4,5	7,5	2764	1,85	4,5	2304	2,20	378,40	43,7	46,5		274	486	0712/12091	
4,1	4,9	8,2	2562	2,00	4,9	2135	2,35	345,45	45,2	46,5		261	546	0712/13090	
4,7	5,6	9,4	2235	2,25	5,6	1863	2,70	303,55	47,3	46,5				0715/12073	
5,2	6,3	11	2020	2,50	6,3	1683	3,00	271,33	48,4	46,5				0712/16087	
6,0	7,2	12	1751	2,90	7,2	1459	3,45	235,63	49,7	46,5				0712/18085	
					3,1	3367	0,85	554,50	**	36,8		ASA 86C 70 91S4 ASA 86C IA90 ARA 86C 70 91S4 ARA 86C IA90	114	266	0510/11071
					3,4	3126	0,90	501,14	**	36,8			100	546	0510/12070
3,1	3,7	6,2	3389	0,85	3,7	2824	1,00	455,98	**	36,8			144	486	0510/13069
3,7	4,5	7,5	2839	1,00	4,5	2366	1,20	379,43	15,3	36,8	130		546	0512/12053	
4,1	5,0	8,3	2562	1,10	5,0	2135	1,35	343,64	21,8	36,8				0512/13052	
4,7	5,7	9,4	2235	1,30	5,7	1863	1,55	300,68	26,9	36,8				0515/12042	
5,4	6,5	11	1945	1,45	6,5	1621	1,75	263,10	30,3	36,8				0512/16049	
6,3	7,6	13	1667	1,70	7,6	1390	2,05	224,32	32,9	36,8				0512/18047	
7,3	8,8	15	1439	1,95	8,8	1199	2,35	193,30	34,6	36,8				0512/20045	
8,6	10	17	1222	2,30	10	1018	2,80	165,68	35,5	36,8				0510/28054	
10	12	20	1051	2,70	12	875	3,20	141,33	35,9	36,8			0510/31051		
					5,3	1990	0,80	324,42	**	24,5	ASA 76C 70 91S4 ASA 76C IA90 ARA 76C 70 91S4 ARA 76C IA90	73	266	0512/12053	
					5,8	1824	0,85	293,82	**	24,5		60	546	0512/13052	
5,5	6,6	11	1910	0,80	6,6	1592	0,95	257,09	**	24,5		89	486	0515/12042	
6,3	7,6	13	1667	0,90	7,6	1390	1,10	224,96	8,8	24,5		76	546	0512/16049	
7,4	8,9	15	1420	1,10	8,9	1183	1,30	191,80	15,0	24,5				0512/18047	
8,6	10	17	1222	1,25	10	1018	1,50	165,27	17,0	24,5			0512/20045		
9,7	12	19	1083	1,20	12	902	1,45	97,66	17,7	24,5	ASA 76A 70 91L6 ASA 76A IA90 ARA 76A 70 91L6 ARA 76A IA90	74	262	0710/11117	
11	13	21	991	1,55	13	826	1,85	88,76	18,1	24,5		58	546	0710/12116	
12	14	23	906	1,70	14	755	2,00	81,22	18,5	24,5		90	486	0710/13115	
14	16	27	772	1,95	16	644	2,35	69,63	19,0	24,5		74	546	0712/12091	
15	18	30	705	2,15	18	588	2,60	63,57	19,2	24,5				0712/13090	
15	17	29	724	1,80	17	604	2,15	97,66	19,1	24,5	ASA 76A 70 91S4 ASA 76A IA90 ARA 76A 70 91S4 ARA 76A IA90	71	262	0710/11117	
16	19	32	657	2,30	19	547	2,75	88,76	19,3	24,5		58	546	0710/12116	
18	21	35	600	2,50	21	500	3,00	81,22	19,4	24,5		87	486	0710/13115	
20	25	41	515	2,95	25	429	3,50	69,63	19,6	24,5		74	546	0712/12091	
					11	952	0,85	102,22	**	20,3		ASA 66A 70 91L6 ASA 66A IA90 ARA 66A 70 91L6 ARA 66A IA90	52	262	0607/12128
10	12	20	1040	0,80	12	867	0,95	93,62	**	20,3	35		546	0607/13127	
12	14	23	913	0,90	14	761	1,10	81,89	4,3	20,3	60		486	0610/11094	
13	15	25	827	1,00	15	689	1,20	74,27	8,2	20,3	43		546	0610/12093	

4

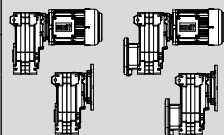
$P_N = 1,1 \text{ kW} / 1,5 \text{ HP}$



50 - 60 - 100 Hz 1,1 - 1,3 - 2,2 kW					60 Hz 1,1 kW			i	bei/at 50 Hz ($F_a=0$) ($F_r=0$)			m kg		ZT Code
n_{50} min ⁻¹	n_{60} min ⁻¹	n_{100} min ⁻¹	M_2 Nm	f_B	n_{60} min ⁻¹	M_2 Nm	f_B		F_{rN} kN	F_{aN} kN				
					15	695	0,85	112,39	8,0	20,3	ASA 66A 70 91S4 ASA 66A IA90 ARA 66A 70 91S4 ARA 66A IA90	48 35 56 43	262 546 486 546	0607/11129
14	17	28	756	1,05	17	630	1,25	102,22	10,2	20,3				0607/12128
15	18	30	691	1,20	18	576	1,40	93,62	11,6	20,3				0607/13127
17	21	35	607	1,35	21	506	1,60	81,89	12,1	20,3				0610/11094
19	23	38	550	1,50	23	458	1,75	74,27	12,5	20,3				0610/12093
21	25	42	503	1,60	25	419	1,95	67,82	12,7	20,3				0610/13092
25	30	49	425	1,90	30	354	2,30	57,50	13,1	20,3				0612/12072
27	33	54	388	2,10	33	323	2,50	52,34	13,2	20,3				0612/13071
31	37	61	342	2,35	37	285	2,85	46,32	13,4	20,3				0615/12058
35	42	70	301	2,70	42	251	3,20	40,73	13,5	20,3				0612/16068
					22	489	0,85	79,36	4,7	11,6	ASA 56A 70 91S4 ASA 56A IA90 ARA 56A 70 91S4 ARA 56A IA90	34 20 39 25	260 546 486 546	0507/12097
					24	447	0,9	72,50	6,8	11,6				0507/13096
22	27	45	469	0,90	27	391	1,05	63,37	8,5	11,6				0510/11071
25	30	50	424	0,95	30	353	1,15	57,27	9,5	11,6				0510/12070
27	33	55	386	1,05	33	322	1,25	52,11	10,1	11,6				0510/13069
33	39	66	321	1,25	39	268	1,50	43,36	10,0	11,6				0512/12053
36	43	72	290	1,40	43	242	1,70	39,27	9,7	11,6				0512/13052
41	50	83	254	1,60	50	212	1,90	34,36	9,3	11,6				0515/12042
47	57	95	223	1,80	57	185	2,20	30,07	9,0	11,6				0512/16049
55	67	111	190	2,15	67	158	2,55	25,64	8,6	11,6				0512/18047
64	77	129	163	2,45	77	136	2,95	22,09	8,2	11,6	0512/20045			
75	90	150	140	2,90	90	117	3,45	18,94	7,9	11,6	0510/28054			
88	106	176	120	3,35	106	100	4,05	16,15	7,5	11,6	0510/31051			
103	124	207	102	2,80	124	85	3,35	13,74	7,1	11,6	0512/18047			
120	144	240	88	3,20	144	73	3,85	11,84	6,8	11,1	0512/20045			
140	168	280	75	3,70	168	63	4,45	10,15	6,5	10,6	0510/28054			
164	197	328	64	4,30	197	53	5,15	8,66	6,2	10,1	0510/31051			
191	229	382	55	4,90	229	46	5,90	7,43	5,9	9,7	0510/34048			
222	266	444	47	5,60	266	39	6,75	6,40	5,6	9,2	0510/37045			
					38	274	0,85	44,56	5,3	7,3	ASA 46A 70 91S4 ASA 46A IA90	30 16	260 546	0410/13054
39	47	78	271	0,85	47	226	1,00	36,65	5,1	7,3				0412/12041
43	52	86	244	0,95	52	204	1,10	33,01	5,0	7,3				0412/13040
50	60	99	212	1,05	60	176	1,25	28,61	4,8	7,3				0415/12032
57	69	115	184	1,20	69	153	1,45	24,81	4,7	7,3				0412/16037
68	82	136	154	1,45	82	129	1,75	20,86	4,5	7,3				0412/18035
80	96	161	131	1,70	96	109	2,05	17,70	4,3	7,3				0412/20033
95	114	190	111	2,00	114	92	2,40	14,94	4,1	7,0				0410/28039
114	137	229	92	1,15	137	77	1,40	12,42	3,8	6,6	0412/12041			
127	152	254	83	1,25	152	69	1,50	11,19	3,7	6,4	0412/13040			
146	176	293	72	1,45	176	60	1,75	9,70	3,6	6,2	0415/12032			
169	203	338	62	1,65	203	52	2,00	8,41	3,5	6,0	0412/16037			
201	241	402	52	1,95	241	44	2,30	7,07	3,3	5,7	0412/18035			
237	284	473	44	2,10	284	37	2,50	6,00	3,1	5,4	0412/20033			
280	336	561	37	2,20	336	31	2,65	5,07	3,0	5,2	0410/28039			
336	404	673	31	2,35	404	26	2,85	4,22	2,8	4,9	0410/31036			

P_N = 1,5 kW / 2,0 HP

50 - 60 - 100 Hz (100 Hz) ¹⁾ 1,5 - 1,8 - 3,0 kW					60 Hz 1,5 kW			i	bei/at 50 Hz (F ₀ =0) (F _r =0)			m kg		ZT Code	
n ₅₀ min ⁻¹	n ₆₀ min ⁻¹	n ₁₀₀ min ⁻¹	M ₂ Nm	f _B	n ₆₀ min ⁻¹	M ₂ Nm	f _B		F _{rN} kN	F _{aN} kN					
1,1	1,3	2,2	11672	1,20	1,3	9727	1,45	880,24	85,7	150,0	FSA 137C 70 101L6	506	268	0810/13133	
1,3	1,5	2,5	9775	1,45	1,5	8146	1,75	752,84	94,3	150,0	FSA 137C IAK100	487	546	0812/12105	
1,4	1,7	2,8	9040	1,55	1,7	7533	1,90	688,31	95,6	150,0	FRA 137C 70 101L6	654	486	0812B13104	
1,6	1,9	3,1	7829	1,80	1,9	6524	2,15	609,44	97,5	150,0	FRA 137C IAK100	635	546	0815B12085	
					1,3	9928	0,85	1328,73	**	66,0	FSA 131D 70 91L4	328	272	0515/12042	
					1,5	9082	0,90	1162,64	**	66,0	FSA 131D IA90	312	546	0512/16049	
1,4	1,7	2,9	9285	0,90	1,7	7737	1,05	991,27	24,4	66,0	FRA 131D 70 91L4	408	486	0512/18047	
1,7	2,0	3,3	7584	1,10	2,0	6320	1,30	854,18	53,4	66,0	FRA 131D IA90	392	546	0512/20045	
2,0	2,3	3,9	6407	1,25	2,3	5339	1,50	732,16	64,0	66,0				0510/28054	
2,2	2,7	4,4	6511	1,25	2,7	5426	1,50	431,55	63,6	66,0	FSA 131C 70 101L6	330	268	0810/13133	
2,6	3,1	5,2	5510	1,50	3,1	4591	1,75	369,09	66,3	66,0	FSA 131C IAK100	311	546	0812/12105	
2,8	3,4	5,7	5116	1,60	3,4	4263	1,90	337,46	67,1	66,0	FRA 131C 70 101L6	410	486	0812B13104	
3,2	3,8	6,4	4477	1,80	3,8	3730	2,15	298,79	68,4	66,0	FRA 131C IAK100	391	546	0815B12085	
					2,2	6632	0,80	530,74	**	46,5	FSA 111C 70 101L6	221	268	0710/11117	
					2,4	5969	0,85	482,36	**	46,5	FSA 111C IAK100	202	546	0710/12116	
2,2	2,6	4,3	6511	0,80	2,6	5426	0,95	441,41	**	46,5	FRA 111C 70 101L6	282	486	0710/13115	
2,5	3,0	5,0	5730	0,90	3,0	4775	1,05	378,40	**	46,5	FRA 111C IAK100	263	546	0712/12091	
2,7	3,2	5,4	5306	0,95	3,2	4421	1,15	530,74	**	46,5				0710/11117	
3,0	3,6	5,9	4775	1,05	3,6	3979	1,30	482,36	6,9	46,5				0710/12116	
3,2	3,9	6,5	4477	1,15	3,9	3730	1,35	441,41	19,7	46,5				0710/13115	
3,8	4,5	7,6	3770	1,35	4,5	3141	1,60	378,40	33,2	46,5	FSA 111C 70 91L4	216	268	0712/12091	
4,1	5,0	8,3	3494	1,45	5,0	2912	1,75	345,45	36,7	46,5	FSA 111C IA90	200	546	0712/13090	
4,7	5,7	9,4	3048	1,65	5,7	2540	2,00	303,55	41,3	46,5	FRA 111C 70 91L4	277	486	0715/12073	
5,3	6,3	11	2703	1,85	6,3	2252	2,25	271,33	44,2	46,5	FRA 111C IA90	261	546	0712/16087	
6,1	7,3	12	2348	2,15	7,3	1957	2,60	235,63	46,6	46,5				0712/18085	
6,9	8,3	14	2076	2,45	8,3	1730	2,90	207,08	48,2	46,5				0712B20083	
8,3	9,9	17	1726	2,90	9,9	1438	3,50	173,33	49,8	46,5				0715/19066	
					4,5	3141	0,90	379,43	**	36,8					0512/12053
4,2	5,0	8,3	3411	0,85	5,0	2842	1,00	343,64	**	36,8	ASA 86C 70 91L4	117	266	0512/13052	
4,8	5,7	9,5	2984	0,95	5,7	2487	1,15	300,68	9,9	36,8	ASA 86C IA90	100	546	0515/12042	
5,4	6,5	11	2653	1,10	6,5	2211	1,30	263,10	19,9	36,8	ARA 86C 70 91L4	147	486	0512/16049	
6,4	7,6	13	2238	1,30	7,6	1865	1,55	224,32	26,9	36,8	ARA 86C IA90	130	546	0512/18047	
7,4	8,9	15	1936	1,45	8,9	1613	1,75	193,30	30,4	36,8				0512/20045	
8,6	10	17	1666	1,70	10	1388	2,05	165,68	32,9	36,8				0510/28054	
9,8	12	20	1462	1,60	12	1218	1,90	97,66	34,4	36,8	ASA 86A 70 101L6	121	262	0810/13133	
11	14	23	1257	2,25	14	1047	2,70	83,52	35,0	36,8	ASA 86A IAK100	102	546	0812/12105	
13	15	25	1146	2,45	15	955	2,95	76,36	34,1	36,8	ARA 86A 70 101L6	151	486	0812B13104	
14	17	28	1016	2,80	17	847	3,35	67,61	33,0	36,8	ARA 86A IAK100	132	546	0815B12085	
					7,6	1865	0,85	224,96	**	24,5	ASA 76C 70 91L4	76	266	0512/16049	
7,5	8,9	15	1910	0,80	8,9	1592	0,95	191,80	**	24,5	ASA 76C IA90	60	546	0512/18047	
8,7	10	17	1647	0,95	10	1372	1,10	165,27	9,6	24,5	ARA 76C 70 91L4	92	486	0512/20045	
											ARA 76C IA90	76	546		
9,8	12	20	1462	0,90	12	1218	1,10	97,66	14,2	24,5	ASA 76A 70 101L6	79	262	0710/11117	
11	13	22	1326	1,15	13	1105	1,40	88,76	16,4	24,5	ASA 76A IAK100	60	546	0710/12116	
12	14	24	1214	1,25	14	1012	1,50	81,22	17,0	24,5	ARA 76A 70 101L6	95	486	0710/13115	
14	17	27	1046	1,45	17	871	1,75	69,63	17,9	24,5	ARA 76A IAK100	76	546	0712/12091	
15	18	29	981	1,35	18	818	1,60	97,66	18,2	24,5				0710/11117	
16	19	32	890	1,70	19	741	2,05	88,76	18,5	24,5	ASA 76A 70 91L4	74	262	0710/12116	
18	21	35	814	1,85	21	678	2,25	81,22	18,8	24,5	ASA 76A IA90	58	546	0710/13115	
21	25	41	699	2,15	25	582	2,60	69,63	19,2	24,5	ARA 76A 70 91L4	90	486	0712/12091	
23	27	45	637	2,40	27	531	2,85	63,57	19,3	24,5	ARA 76A IA90	74	546	0712/13090	
26	31	51	560	2,70	31	466	3,25	55,86	19,5	24,5				0715/12073	

4

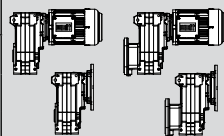
$P_N = 1,5 \text{ kW} / 2,0 \text{ HP}$



50 - 60 - 100 Hz (100 Hz) ¹⁾					60 Hz			i	bei/at 50 Hz			m kg		ZT Code
1,5 - 1,8 - 3,0 kW					1,5 kW				(F _a =0) (F _r =0)					
n ₅₀ min ⁻¹	n ₆₀ min ⁻¹	n ₁₀₀ min ⁻¹	M ₂ Nm	f _B	n ₆₀ min ⁻¹	M ₂ Nm	f _B		F _{rN} kN	F _{aN} kN				
					17	853	0,90	102,22	**	20,3	ASA 66A 70 91L4 ASA 66A IA90 ARA 66A 70 91L4 ARA 66A IA90	52 35 60 43	262 546 486 546	0607/12128
15	18	31	936	0,90	18	780	1,05	93,62	2,1	20,3				0607/13127
18	21	35	819	1,00	21	682	1,20	81,89	8,5	20,3				0610/11094
19	23	39	742	1,10	23	619	1,30	74,27	10,5	20,3				0610/12093
21	25	42	679	1,20	25	566	1,45	67,82	11,7	20,3				0610/13092
25	30	50	575	1,40	30	479	1,70	57,50	12,3	20,3				0612/12072
27	33	55	525	1,55	33	437	1,85	52,34	12,6	20,3				0612/13071
31	37	62	464	1,75	37	386	2,10	46,32	12,9	20,3				0615/12058
35	42	70	408	2,00	42	340	2,40	40,73	13,1	20,3				0612/16068
41	49	81	352	2,30	49	293	2,75	35,14	13,3	20,3				0612/18066
47	56	93	307	2,65	56	256	3,15	30,67	13,5	20,3	0612B20064			
					27	528	0,80	63,37	**	11,6	ASA 56A 70 91L4 ASA 56A IA90 ARA 56A 70 91L4 ARA 56A IA90	37 20 42 25	260 546 486 546	0510/11071
					30	478	0,85	57,27	5,4	11,6				0510/12070
27	33	55	523	0,80	33	436	0,95	52,11	7,2	11,6				0510/13069
33	40	66	434	0,95	40	362	1,15	43,36	9,3	11,6				0512/12053
36	44	73	394	1,05	44	328	1,25	39,27	9,3	11,6				0512/13052
42	50	83	344	1,20	50	287	1,40	34,36	9,0	11,6				0515/12042
48	57	95	301	1,35	57	251	1,60	30,07	8,7	11,6				0512/16049
56	67	112	257	1,60	67	214	1,90	25,64	8,4	11,6				0512/18047
65	78	130	221	1,85	78	185	2,20	22,09	8,0	11,6				0512/20045
76	91	151	190	2,15	91	158	2,55	18,94	7,7	11,6				0510/28054
89	106	177	162	2,50	106	135	3,00	16,15	7,4	11,6	0510/31051			
103	124	206	139	2,90	124	116	3,50	13,86	7,0	11,5	0510/34048			
121	145	242	119	2,35	145	99	2,85	11,84	6,7	10,9	ASA 56S 70 91L4 ASA 56S IA90 ARA 56S 70 91L4 ARA 56S IA90	37 20 42 25	260 546 486 546	0512/20045
141	169	282	102	2,75	169	85	3,30	10,15	6,4	10,4				0510/28054
165	198	330	87	3,15	198	72	3,80	8,66	6,1	10,0				0510/31051
193	231	385	74	3,65	231	62	4,35	7,43	5,8	9,5				0510/34048
223	268	447	64	4,15	268	53	5,00	6,40	5,6	9,1				0510/37045
50	60	100	287	0,80	52	276	0,80	33,01	4,6	7,3	ASA 46A 70 91L4 ASA 46A IA90	32 16	260 546	0412/13040
58	69	115	249	0,90	60	239	0,95	28,61	4,5	7,3				0415/12032
69	82	137	209	1,10	69	207	1,10	24,81	4,4	7,3				0412/16037
81	97	162	177	1,25	82	174	1,30	20,86	4,2	7,2				0412/18035
96	115	191	150	1,50	97	148	1,50	17,70	4,1	7,0				0412/20033
115	138	230	125	1,80	115	125	1,80	14,94	3,9	6,7				0410/28039
128	153	256	112	0,95	138	104	2,15	12,46	3,8	6,4	0410/31036			
128	153	256	112	0,95	153	93	1,15	11,19	3,6	6,2	ASA 46S 70 91L4 ASA 46S IA90	32 16	260 546	0412/13040
148	177	295	97	1,10	153	93	1,15	11,19	3,6	6,2				0415/12032
170	204	340	84	1,25	177	81	1,30	9,70	3,5	6,0				0412/16037
202	243	405	71	1,45	204	70	1,50	8,41	3,4	5,8				0412/18035
238	286	477	60	1,55	243	59	1,70	7,07	3,2	5,5				0412/20033
282	339	565	51	1,65	286	50	1,85	6,00	3,1	5,3				0410/28039
339	406	677	42	1,75	339	42	1,95	5,07	2,9	5,0				0410/31036
					406	35	2,10	4,22	2,8	4,8				

P_N = 2,2 kW / 3,0 HP

50 - 60 - 100 Hz 2,2 - 2,6 - 4,4 kW					60 Hz 2,2 kW			i	bei/at 50 Hz (F _a =0) (F _r =0)			m kg		ZT Code			
n ₅₀ min ⁻¹	n ₆₀ min ⁻¹	n ₁₀₀ min ⁻¹	M ₂ Nm	f _B	n ₆₀ min ⁻¹	M ₂ Nm	f _B		F _{rN} kN	F _{aN} kN							
1,1	1,3	2,2	17367	0,85	1,3	14472	1,00	880,24	**	150,0	FSA 137C 70 113M6	516	268	0810/13133			
1,3	1,5	2,5	14605	1,00	1,5	12171	1,20	752,84	61,3	150,0	FSA 137C IAK112	487	546	0812/12105			
1,4	1,7	2,8	13534	1,05	1,7	11278	1,25	688,31	71,9	150,0	FRA 137C 70 113M6	664	486	0812B13104			
1,6	1,9	3,1	11769	1,20	1,9	9808	1,45	609,44	85,1	150,0	FRA 137C IAK112	635	546	0815B12085			
1,6	2,0	3,3	11769	1,20	2,0	9808	1,45	880,24	85,1	150,0	FSA 137C 70 101L4	508	268	0810/13133			
1,9	2,3	3,8	9810	1,45	2,3	8175	1,75	752,84	94,2	150,0	FSA 137C IAK100	487	546	0812/12105			
2,1	2,5	4,2	8821	1,60	2,5	7351	1,95	688,31	95,9	150,0	FRA 137C 70 101L4	656	486	0812B13104			
2,4	2,8	4,7	7639	1,85	2,8	6366	2,20	609,44	97,7	150,0	FRA 137C IAK100	635	546	0815B12085			
2,2	2,7	4,4	9550	0,85	2,7	7958	1,05	431,55	14,3	66,0	FSA 131C 70 113M6	340	268	0810/13133			
2,6	3,1	5,2	8081	1,00	3,1	6734	1,20	369,09	47,3	66,0	FSA 131C IAK112	311	546	0812/12105			
2,8	3,4	5,7	7504	1,10	3,4	6253	1,30	337,46	54,3	66,0	FRA 131C 70 113M6	420	486	0812B13104			
3,2	3,8	6,4	6566	1,25	3,8	5471	1,50	298,79	63,1	66,0	FRA 131C IAK112	391	546	0815B12085			
3,3	4,0	6,7	6367	1,30	4,0	5306	1,55	431,55	64,2	66,0	FSA 131C 70 101L4 FSA 131C IAK100 FRA 131C 70 101L4 FRA 131C IAK100	332 311 412 391	268 546 486 546	0810/13133			
3,9	4,7	7,8	5387	1,50	4,7	4489	1,80	369,09	63,5	66,0				0812/12105			
4,3	5,1	8,6	4886	1,65	5,1	4072	2,00	337,46	62,0	66,0				0812B13104			
4,8	5,8	9,7	4377	1,85	5,8	3648	2,20	298,79	60,4	66,0				0815B12085			
5,8	6,9	12	3622	2,25	6,9	3019	2,70	249,58	57,5	66,0				0817/12071			
6,4	7,6	13	3283	2,45	7,6	2736	2,95	227,13	56,1	66,0				0817/13070			
7,1	8,5	14	2959	2,75	8,5	2466	3,25	204,58	54,5	66,0				0812B20097			
					3,3	6485	0,80	530,74	**	46,5				FSA 111C 70 101L4 FSA 111C IAK100 FRA 111C 70 101L4 FRA 111C IAK100	223 202 284 263	268 546 486 546	0710/11117
					3,6	5836	0,90	482,36	**	46,5							0710/12116
3,3	3,9	6,5	6367	0,80	3,9	5306	0,95	441,41	**	46,5							0710/13115
3,8	4,6	7,6	5529	0,95	4,6	4607	1,10	378,40	**	46,5	0712/12091						
4,2	5,0	8,4	5002	1,00	5,0	4169	1,20	345,45	**	46,5	0712/13090						
4,8	5,7	9,5	4377	1,15	5,7	3648	1,40	303,55	22,2	46,5	0715/12073						
5,3	6,4	11	3964	1,30	6,4	3303	1,55	271,33	30,3	46,5	0712/16087						
6,1	7,4	12	3444	1,50	7,4	2870	1,75	235,63	37,3	46,5	0712/18085						
7,0	8,4	14	3001	1,70	8,4	2501	2,00	207,08	41,7	46,5	0712B20083						
8,3	10	17	2531	2,00	10	2109	2,40	173,33	45,4	46,5	0715/19066						
9,5	11	19	2212	2,30	11	1843	2,75	152,07	47,4	46,5	0715/21064						
11	13	22	1964	2,55	13	1636	3,10	134,51	46,0	46,5	0715/23062						
13	15	26	1641	3,05	15	1368	3,70	113,23	43,7	46,5	0715/26059						
					5,8	3648	0,80	300,68	**	36,8	ASA 86C 70 101L4 ASA 86C IAK100 ARA 86C 70 101L4 ARA 86C IAK100	124 103 154 133	266 546 486 546	0515/12042			
6,4	7,7	13	3283	0,90	6,6	3183	0,90	263,10	**	36,8				0512/16049			
7,5	9,0	15	2801	1,00	7,7	2736	1,05	224,32	**	36,8				0512/18047			
8,7	11	17	2415	1,20	9,0	2334	1,20	193,30	16,4	36,8				0512/20045			
9,8	12	20	2144	1,10	11	2012	1,40	165,68	24,3	36,8	ASA 86A 70 113M6 ASA 86A IAK112 ARA 86A 70 113M6 ARA 86A IAK112	131 102	262 546	0810/13133			
11	14	23	1843	1,55	14	1536	1,85	83,52	31,3	36,8				0812/12105			
13	15	25	1681	1,70	15	1401	2,00	76,36	32,8	36,8	ASA 86A 70 101L4 ASA 86A IAK100 ARA 86A 70 101L4 ARA 86A IAK100	161 132	486 546	0812B13104			
14	17	28	1490	1,90	17	1242	2,30	67,61	31,9	36,8				0815B12085			
15	18	30	1420	1,65	18	1183	1,95	97,66	31,5	36,8	ASA 76A 70 113M6 ASA 76A IAK112 ARA 76A 70 113M6 ARA 76A IAK112	89 60 105 76	262 546 486 546	0810/13133			
17	21	35	1214	2,35	21	1012	2,80	83,52	30,2	36,8				0812/12105			
19	23	38	1112	2,55	23	926	3,05	76,36	29,5	36,8				0812B13104			
21	26	43	982	2,90	26	818	3,45	67,61	28,5	36,8				0815B12085			
11	13	22	1945	0,80	13	1621	0,95	88,76	**	24,5				89	262	0710/12116	
12	14	24	1781	0,85	14	1484	1,05	81,22	1,8	24,5	60	546	0710/13115				
14	17	27	1534	1,00	17	1278	1,20	69,63	12,7	24,5	105	486	0712/12091				

4

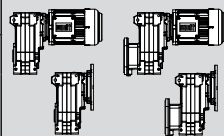
$P_N = 2,2 \text{ kW} / 3,0 \text{ HP}$



50 - 60 - 100 Hz 2,2 - 2,6 - 4,4 kW					60 Hz 2,2 kW			i	bei/at 50 Hz ($F_a=0$) ($F_r=0$)			m kg		ZT Code
n_{50} min ⁻¹	n_{60} min ⁻¹	n_{100} min ⁻¹	M_2 Nm	f_B	n_{60} min ⁻¹	M_2 Nm	f_B		F_{rN} kN	F_{aN} kN				
15	18	30	1420	0,95	18	1183	1,10	97,66	15,0	24,5	ASA 76A 70 101L4 ASA 76A IAK100 ARA 76A 70 101L4 ARA 76A IAK100	81 60 97 76	262 546 486 546	0710/11117
16	20	33	1289	1,20	20	1074	1,40	88,76	16,6	24,5				0710/12116
18	21	36	1180	1,30	21	984	1,55	81,22	17,2	24,5				0710/13115
21	25	42	1010	1,50	25	842	1,80	69,63	18,0	24,5				0712/12091
23	27	46	926	1,65	27	771	1,95	63,57	18,4	24,5				0712/13090
26	31	52	811	1,85	31	676	2,25	55,86	18,8	24,5				0715/12073
29	35	58	727	2,10	35	606	2,50	49,93	18,6	24,5				0712/16087
33	40	67	631	2,40	40	526	2,90	43,36	17,9	24,5				0712/18085
38	46	76	554	2,75	46	462	3,25	38,11	17,2	24,5				0712B20083
					21	995	0,85	81,89	**	20,3	ASA 66A 70 101L4 ASA 66A IAK100 ARA 66A 70 101L4 ARA 66A IAK100	58 37 66 45	262 546 486 546	0610/11094
					23	898	0,90	74,27	**	20,3				0610/12093
21	26	43	986	0,85	26	822	1,00	67,82	**	20,3				0610/13092
25	30	50	837	1,00	30	698	1,15	57,50	7,9	20,3				0612/12072
28	33	55	761	1,10	33	634	1,30	52,34	10,1	20,3				0612/13071
31	37	62	673	1,20	37	561	1,45	46,32	11,7	20,3				0615/12058
36	43	71	592	1,40	43	493	1,65	40,73	12,2	20,3				0612/16068
41	49	82	511	1,60	49	426	1,90	35,14	12,7	20,3				0612/18066
47	57	94	446	1,80	57	372	2,20	30,67	13,0	20,3				0612B20064
56	67	112	374	2,15	67	312	2,60	25,72	13,3	20,3				0615/19051
65	78	129	325	2,50	78	271	3,00	22,36	13,4	20,2				0615/21049
74	89	148	285	2,85	89	237	3,40	19,58	13,3	19,4	0615/23047			
89	107	178	236	3,40	107	197	4,10	16,22	12,6	18,4	0615/26044			
101	121	201	209	3,05	121	174	3,65	14,36	12,1	17,7	ASA 66S 70 101L4 ASA 66S IAK100 ARA 66S 70 101L4 ARA 66S IAK100	58 37 66 45	262 546 486 546	0615/19051
116	139	232	181	3,50	139	151	4,15	12,48	11,6	17,0				0615/21049
132	159	264	159	3,95	159	132	4,75	10,93	11,2	16,3				0615/23047
160	192	319	132	4,70	192	110	5,65	9,05	10,5	15,4				0615/26044
191	229	382	110	5,55	229	92	6,65	7,56	10,0	14,6				0615/29041
227	273	455	92	6,45	273	77	7,75	6,35	9,4	13,8				0615/32038
					40	526	0,80	43,36	0,8	11,6	ASA 56A 70 101L4 ASA 56A IAK100 ARA 56A 70 101L4 ARA 56A IAK100	44 23 49 28	260 546 486 546	0512/12053
					44	476	0,85	39,27	5,5	11,6				0512/13052
42	51	84	499	0,85	51	416	1,00	34,36	7,8	11,6				0515/12042
48	58	96	437	0,95	58	364	1,10	30,07	8,2	11,6				0512/16049
56	68	113	373	1,10	68	310	1,30	25,64	8,0	11,6				0512/18047
65	79	131	321	1,25	79	268	1,50	22,09	7,7	11,6				0512/20045
76	92	153	275	1,50	92	229	1,75	18,94	7,4	11,6				0510/28054
90	107	179	235	1,75	107	196	2,05	16,15	7,1	11,5				0510/31051
104	125	209	202	2,00	125	168	2,40	13,86	6,8	11,0	0510/34048			
122	146	244	172	1,65	146	144	1,95	11,84	6,5	10,5	ASA 56S 70 101L4 ASA 56S IAK100 ARA 56S 70 101L4 ARA 56S IAK100	44 23 49 28	260 546 486 546	0512/20045
142	171	285	148	1,90	171	123	2,25	10,15	6,2	10,1				0510/28054
167	200	334	126	2,20	200	105	2,65	8,66	5,9	9,7				0510/31051
195	233	389	108	2,50	233	90	3,00	7,43	5,7	9,3				0510/34048
226	271	452	93	2,85	271	78	3,45	6,40	5,4	8,9				0510/37045

$P_N = 3,0 \text{ kW} / 4,0 \text{ HP}$

50 - 60 - 100 Hz 3,0 - 3,6 - 6,0 kW					60 Hz 3,0 kW			i	bei/at 50 Hz ($F_o=0$) ($F_r=0$)			m kg		ZT Code
n_{50} min ⁻¹	n_{60} min ⁻¹	n_{100} min ⁻¹	M_2 Nm	f_B	n_{60} min ⁻¹	M_2 Nm	f_B		F_{rN} kN	F_{aN} kN				
1,6	2,0	3,3	16248	0,90	2,0	13540	1,05	880,24	37,5	150,0	FSA 137C 70 101LA4 FSA 137C IAK100 FRA 137C 70 101LA4 FRA 137C IAK100	512 487 660 635	268 546 486 546	0810/13133 0812/12105 0812B13104 0815B12085 0817/12071 0817/13070 0812B20097 0815/19079 0815/21077 0815/23075
1,9	2,3	3,8	13599	1,05	2,3	11332	1,25	752,84	71,3	150,0				
2,1	2,5	4,2	12253	1,15	2,5	10211	1,40	688,31	81,9	150,0				
2,4	2,8	4,7	10634	1,35	2,8	8861	1,60	609,44	91,8	150,0				
2,8	3,4	5,7	9040	1,55	3,4	7533	1,90	509,06	95,6	150,0				
3,1	3,7	6,2	8098	1,75	3,7	6748	2,10	463,29	97,1	150,0				
3,5	4,2	6,9	7098	2,00	4,2	5915	2,40	417,29	98,5	150,0				
4,0	4,8	8,1	6134	2,30	4,8	5112	2,75	357,74	99,6	150,0				
4,6	5,5	9,2	5246	2,70	5,5	4372	3,25	315,48	100,5	150,0				
5,2	6,2	10	4564	3,10	6,2	3803	3,70	280,56	101,1	150,0				
2,8	3,4	5,7	10232	0,80	3,4	8527	0,95	337,46	**	66,0	FSA 131C 70 133S6 FSA 131C IAK132 FRA 131C 70 133S6 FRA 131C IAK132	345 315 425 395	268 546 486 546	0812B13104 0815B12085
3,2	3,9	6,4	8953	0,90	3,9	7461	1,10	298,79	32,7	66,0				
3,3	4,0	6,7	8682	0,95	4,0	7235	1,15	431,55	38,1	66,0				
3,9	4,7	7,8	7346	1,10	4,7	6122	1,35	369,09	56,0	66,0	FSA 131C 70 101LA4 FSA 131C IAK100 FRA 131C 70 101LA4 FRA 131C IAK100	336 311 416 391	268 546 486 546	0810/13133 0812/12105 0812B13104 0815B12085 0817/12071 0817/13070 0812B20097 0815/19079 0815/21077 0815/23075
4,3	5,1	8,6	6663	1,25	5,1	5552	1,45	337,46	58,9	66,0				
4,8	5,8	9,7	5969	1,35	5,8	4974	1,65	298,79	57,6	66,0				
5,8	6,9	12	4940	1,65	6,9	4116	1,95	249,58	55,2	66,0				
6,4	7,6	13	4477	1,80	7,6	3730	2,15	227,13	54,0	66,0				
7,1	8,5	14	4035	2,00	8,5	3363	2,40	204,58	52,7	66,0				
8,2	9,9	17	3494	2,30	9,9	2912	2,75	175,39	50,8	66,0				
9,3	11	19	3081	2,60	11	2567	3,15	154,67	49,2	66,0				
11	13	21	2729	2,95	13	2274	3,55	137,55	47,6	66,0				
4,8	5,7	9,5	5969	0,85	4,6	6283	0,80	378,40	**	46,5				
5,3	6,4	11	5406	0,95	5,0	5685	0,90	345,45	**	46,5				
6,1	7,4	12	4697	1,10	5,7	4974	1,05	303,55	**	46,5				
7,0	8,4	14	4093	1,25	6,4	4505	1,15	271,33	**	46,5				
8,3	10	17	3452	1,45	7,4	3914	1,30	235,63	11,8	46,5				
9,5	11	19	3016	1,70	8,4	3411	1,50	207,08	28,1	46,5				
11	13	22	2678	1,90	10	2877	1,75	173,33	37,2	46,5				
13	15	26	2238	2,25	11	2513	2,00	152,07	41,6	46,5				
15	18	30	1910	2,65	13	2231	2,25	134,51	44,4	46,5				
18	21	35	1637	3,10	15	1865	2,70	113,23	42,5	46,5				
8,7	11	17	3293	0,90	7,7	3730	0,80	224,32	**	36,8	ASA 86C 70 101LA4 ASA 86C IAK100 ARA 86C 70 101LA4 ARA 86C IAK100	128 103 158 133	266 546 486 546	0512/18047 0512/20045 0510/28054
					9,0	3183	0,90	193,30	**	36,8				
					11	2744	1,05	165,68	**	36,8				
15	18	30	1936	1,20	18	1613	1,45	97,66	30,3	36,8	ASA 86A 70 101LA4 ASA 86A IAK100 ARA 86A 70 101LA4 ARA 86A IAK100	127 102 157 132	262 546 486 546	0810/13133 0812/12105 0812B13104 0815B12085 0817/12071 0817/13070 0812B20097
17	21	35	1656	1,70	21	1380	2,05	83,52	29,2	36,8				
19	23	38	1516	1,85	23	1263	2,25	76,36	28,6	36,8				
21	26	43	1339	2,10	26	1116	2,55	67,61	27,7	36,8				
26	31	51	1119	2,55	31	933	3,05	56,48	26,4	36,8				
28	34	56	1020	2,75	34	850	3,30	51,40	25,7	36,8				
31	38	62	918	3,05	38	765	3,70	46,30	25,0	36,6				

4

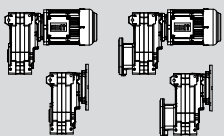
$P_N = 3,0 \text{ kW} / 4,0 \text{ HP}$



50 - 60 - 100 Hz 3,0 - 3,6 - 6,0 kW					60 Hz 3,0 kW			i	bei/at 50 Hz ($F_a=0$) ($F_r=0$)			m kg		ZT Code
n_{50} min ⁻¹	n_{60} min ⁻¹	n_{100} min ⁻¹	M_2 Nm	f_B	n_{60} min ⁻¹	M_2 Nm	f_B		F_{rN} kN	F_{aN} kN				
16	20	33	1758	0,90	18	1613	0,80	97,66	**	24,5	ASA 76A 70 101LA4 ASA 76A IAK100 ARA 76A 70 101LA4 ARA 76A IAK100	85 60 101 76	262 546 486 546	0710/11117
18	21	36	1610	0,95	20	1465	1,05	88,76	4,3	24,5				0710/12116
21	25	42	1377	1,10	21	1341	1,15	81,22	10,7	24,5				0710/13115
23	27	46	1262	1,20	25	1148	1,35	69,63	15,7	24,5				0712/12091
26	31	52	1106	1,40	27	1052	1,45	63,57	16,8	24,5				0712/13090
29	35	58	991	1,55	31	922	1,65	55,86	17,6	24,5				0715/12073
33	40	67	860	1,75	35	826	1,85	49,93	17,9	24,5				0712/16087
38	46	76	756	2,00	40	717	2,1	43,36	17,3	24,5				0712/18085
45	54	91	632	2,40	46	630	2,4	38,11	16,7	24,4				0712B20083
52	62	103	555	2,75	54	527	2,85	31,90	16,0	23,4				0715/19066
58	70	117	491	3,10	62	463	3,25	27,98	15,4	22,6	0715/21064			
					70	409	3,70	24,75	14,9	21,8	0715/23062			
28	33	55	1038	0,80	30	951	0,85	57,50	**	20,3	ASA 66A 70 101LA4 ASA 66A IAK100 ARA 66A 70 101LA4 ARA 66A IAK100	62 37 70 45	262 546 486 546	0612/12072
31	37	62	918	0,90	33	865	0,95	52,34	**	20,3				0612/13071
36	43	71	807	1,00	37	765	1,05	46,32	3,9	20,3				0615/12058
41	49	82	697	1,15	43	673	1,20	40,73	8,9	20,3				0612/16068
47	57	94	608	1,35	49	581	1,40	35,14	11,5	20,3				0612/18066
56	67	112	510	1,60	57	507	1,60	30,67	12,1	20,3				0612B20064
65	78	129	443	1,85	67	425	1,90	25,72	12,7	20,3				0615/19051
74	89	148	388	2,10	78	370	2,20	22,36	13,0	19,6				0615/21049
89	107	178	322	2,50	89	324	2,50	19,58	13,0	18,9				0615/23047
101	121	201	285	2,25	107	268	3,00	16,22	12,3	18,0				0615/26044
116	139	232	247	2,55	121	237	2,70	14,36	11,9	17,3	ASA 66S 70 101LA4 ASA 66S IAK100 ARA 66S 70 101LA4 ARA 66S IAK100	62 37 70 45	262 546 486 546	0615/19051
132	159	264	217	2,90	116	206	3,05	12,48	11,4	16,6				0615/21049
160	192	319	180	3,45	132	181	3,45	10,93	11,0	16,0				0615/23047
191	229	382	150	4,05	160	150	4,15	9,05	10,4	15,2				0615/26044
227	273	455	126	4,75	191	125	4,85	7,56	9,8	14,4				0615/29041
					227	105	5,70	6,35	9,3	13,6				0615/32038
56	68	*113	508	0,80	58	496	0,85	30,07	4,3	11,6	ASA 56A 70 101LA4 ASA 56A IAK100 ARA 56A 70 101LA4 ARA 56A IAK100	48 23 53 28	260 546 486 546	0512/16049
65	79	*131	438	0,95	68	423	0,95	25,64	7,5	11,6				0512/18047
76	92	*153	375	1,10	79	365	1,10	22,09	7,3	11,6				0512/20045
90	107	*179	320	1,25	92	313	1,30	18,94	7,1	11,3				0510/28054
104	125	*209	275	1,50	107	267	1,50	16,15	6,8	10,9				0510/31051
					104	229	1,75	13,86	6,6	10,6				0510/34048
122	146	*244	235	1,20	146	196	1,45	11,84	6,3	10,1	ASA 56S 70 101LA4 ASA 56S IAK100 ARA 56S 70 101LA4 ARA 56S IAK100	48 23 53 28	260 546 486 546	0512/20045
142	171	*285	201	1,40	122	171	1,65	10,15	6,0	9,7				0510/28054
167	200	*334	172	1,60	142	168	1,65	8,66	5,8	9,4				0510/31051
195	233	*389	147	1,85	167	143	1,95	7,43	5,6	9,0				0510/34048
226	271	*452	127	2,10	195	123	2,20	6,40	5,3	8,7				0510/37045
					226	106	2,55	6,40	5,3	8,7				

P_N = 4,0 kW / 5,5 HP

50 - 60 - 100 Hz 4,0 - 4,8 - 8,0 kW					60 Hz 4,0 kW			i	bei/at 50 Hz (F ₀ =0) (F _r =0)			m kg		ZT Code
n ₅₀ min ⁻¹	n ₆₀ min ⁻¹	n ₁₀₀ min ⁻¹	M ₂ Nm	f _B	n ₆₀ min ⁻¹	M ₂ Nm	f _B		F _{rN} kN	F _{aN} kN				
1,9	2,3	3,8	18318	0,80	2,0	18239	0,80	880,24	**	150,0	FSA 137C 70 113M4 FSA 137C IAK112 FRA 137C 70 113M4 FRA 137C IAK112	520 487 668 635	268 546 486 546	0810/13133
2,1	2,5	4,2	16540	0,85	2,3	15265	0,95	752,84	**	150,0				0812/12105
2,4	2,8	4,7	14384	1,00	2,5	13783	1,05	688,31	31,0	150,0				0812B13104
2,8	3,4	5,7	12253	1,15	2,8	11986	1,20	609,44	63,7	150,0				0815B12085
3,1	3,7	6,2	10999	1,30	3,4	10211	1,40	509,06	81,9	150,0				0817/12071
3,5	4,2	6,9	9682	1,45	3,7	9166	1,55	463,29	89,8	150,0				0817/13070
4,0	4,8	8,1	8385	1,70	4,2	8069	1,75	417,29	94,4	150,0				0812B20097
4,6	5,5	9,2	7216	1,95	4,8	6988	2,05	357,74	96,6	150,0				0815/19079
5,2	6,2	10	6305	2,25	5,5	6014	2,35	315,48	98,3	150,0				0815/21077
6,1	7,3	12	5286	2,65	6,2	5254	2,70	280,56	99,4	150,0				0815/23075
5,7	6,8	11	6702	2,10	7,3	4405	3,20	238,26	100,5	150,0	0815/26072			
6,2	7,5	12	6161	2,30	6,8	5585	2,55	169,39	99,0	150,0	FSA 137A 70 133M6 FSA 137A IAK132 FRA 137A 70 133M6 FRA 137A IAK132	505 465 653 613	264 546 486 546	1317/12126
7,0	8,3	14	5457	2,60	7,5	5134	2,75	155,12	99,6	150,0				1317/13125
7,7	9,3	16	4961	2,85	8,3	4548	3,10	138,74	100,3	150,0				1325/10086
8,5	10	17	4494	3,15	9,3	4134	3,40	124,66	100,8	150,0				1325/11085
					10	3745	3,75	112,93	101,2	150,0				1325/12084
3,9	4,7	7,8	9795	0,85	4,0	9646	0,85	431,55	**	66,0	FSA 131C 70 113M4 FSA 131C IAK112 FRA 131C 70 113M4 FRA 131C IAK112	344 311 424 391	268 546 486 546	0810/13133
4,3	5,1	8,6	8884	0,95	4,7	8162	1,00	369,09	**	66,0				0812/12105
4,8	5,8	9,7	7958	1,05	5,1	7403	1,10	337,46	34,2	66,0				0812B13104
5,8	6,9	12	6586	1,25	5,8	6632	1,25	298,79	48,9	66,0				0815B12085
6,4	7,6	13	5969	1,35	6,9	5489	1,50	249,58	52,3	66,0				0817/12071
7,1	8,5	14	5380	1,50	7,6	4974	1,65	227,13	51,3	66,0				0817/13070
8,2	9,9	17	4659	1,75	8,5	4484	1,80	204,58	50,3	66,0				0812B20097
9,3	11	19	4108	1,95	9,9	3882	2,10	175,39	48,7	66,0				0815/19079
9,3	11	19	4108	1,95	11	3423	2,35	154,67	47,4	66,0				0815/21077
11	13	21	3638	2,20	13	3032	2,65	137,55	46,1	66,0				0815/23075
12	14	23	3293	2,25	14	2744	2,70	83,05	44,9	66,0	FSA 131A 70 133M6 FSA 131A IAK132 FRA 131A 70 133M6 FRA 131A IAK132	329 289 409 369	264 546 486 546	1317/12126
13	15	25	3008	2,70	15	2507	3,20	76,05	43,9	65,3				1317/13125
14	17	28	2690	3,00	17	2242	3,60	68,02	42,7	63,4				1325/10086
6,1	7,4	12	6262	0,80	5,7	6632	0,80	303,55	**	46,5	FSA 111C 70 113M4 FSA 111C IAK112 FRA 111C 70 113M4 FRA 111C IAK112	235 202 296 263	268 546 486 546	0715/12073
7,0	8,4	14	5457	0,95	6,4	6006	0,85	271,33	**	46,5				0712/16087
8,3	10	17	4602	1,10	7,4	5219	1,00	235,63	**	46,5				0712/18085
9,7	12	20	3938	1,05	8,4	4548	1,10	207,08	**	46,5				0712B20083
					10	3835	1,35	173,33	15,7	46,5				0715/19066
11	13	22	3505	1,45	12	3282	1,25	99,06	30,7	46,5	FSA 111A 70 133M6 FSA 111A IAK132 FRA 111A 70 133M6 FRA 111A IAK132	236 196 297 257	264 546 486 546	1112B13153
13	16	26	2938	1,75	13	2920	1,75	88,38	36,6	46,5				1115B12126
14	17	28	2690	1,90	16	2449	2,05	74,35	40,9	46,5				1117/12106
16	19	32	2403	2,10	17	2242	2,25	67,98	40,0	46,5				1117/13105
18	21	36	2146	2,35	19	2002	2,50	60,60	38,9	46,5				1125/10072
20	24	39	1939	2,60	21	1788	2,80	54,33	37,8	46,5				1125/11071
					24	1616	3,10	49,10	36,8	46,5				1125/12070
12	14	24	3210	0,90	11	3659	0,80	165,68	**	36,8	ASA 86C 70 113M4 ASA 86C IAK112 ARA 86C 70 113M4 ARA 86C IAK112	136 103 166 133	266 546 486 546	0510/28054
14	17	28	2768	1,05	12	3121	0,90	141,33	**	36,8				0510/31051
15	18	30	2581	0,90	14	2675	1,05	121,28	**	36,8				0510/34048
17	21	35	2208	1,30	17	2307	1,25	104,48	17,2	36,8				0510/37045
17	21	35	2208	1,30	18	2151	1,10	97,66	21,4	36,8	ASA 86A 70 113M4 ASA 86A IAK112 ARA 86A 70 113M4 ARA 86A IAK112	135 102 165 132	262 546 486 546	0810/13133
19	23	38	2021	1,40	21	1840	1,55	83,52	27,3	36,8				0812/12105
21	26	43	1785	1,60	23	1684	1,70	76,36	27,4	36,8				0812B13104
26	31	51	1492	1,90	26	1488	1,90	67,61	26,6	36,8				0815B12085
28	34	56	1359	2,10	31	1243	2,30	56,48	25,5	36,8				0817/12071
31	38	62	1224	2,30	34	1133	2,50	51,40	25,0	36,6				0817/13070
36	44	73	1049	2,70	38	1020	2,75	46,30	24,3	35,6				0812B20097
					44	875	3,25	39,69	23,3	34,2				0815/19079

4

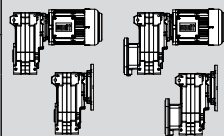
P_N = 4,0 kW / 5,5 HP



50 - 60 - 100 Hz 4,0 - 4,8 - 8,0 kW					60 Hz 4,0 kW			i	bei/at 50 Hz (F _a =0) (F _r =0)			m kg		ZT Code
n ₅₀ min ⁻¹	n ₆₀ min ⁻¹	n ₁₀₀ min ⁻¹	M ₂ Nm	f _B	n ₆₀ min ⁻¹	M ₂ Nm	f _B		F _{rN} kN	F _{aN} kN				
					20	1953	0,80	88,76	**	24,5	ASA 76A 70 113M4 ASA 76A IAK112 ARA 76A 70 113M4 ARA 76A IAK112	93 60 109 76	262 546 486 546	0710/12116
					21	1788	0,85	81,22	**	24,5				0710/13115
21	25	42	1837	0,85	25	1530	1,00	69,63	**	24,5				0712/12091
23	27	46	1683	0,90	27	1402	1,10	63,57	8,3	24,5				0712/13090
26	31	52	1475	1,05	31	1229	1,25	55,86	13,9	24,5				0715/12073
29	35	58	1322	1,15	35	1101	1,40	49,93	16,4	24,5				0712/16087
33	40	67	1147	1,35	40	956	1,60	43,36	16,5	24,1				0712/18085
38	46	76	1008	1,50	46	840	1,80	38,11	16,0	23,4				0712B20083
45	54	91	843	1,80	54	703	2,15	31,90	15,4	22,5				0715/19066
52	62	103	740	2,05	62	617	2,45	27,98	14,9	21,8				0715/21064
58	70	117	654	2,30	70	545	2,80	24,75	14,5	21,2				0715/23062
69	83	139	550	2,75	83	459	3,30	20,84	13,8	20,2				0715/26059
82	98	163	469	3,25	98	391	3,85	17,73	13,3	19,4				0715/29056
95	114	190	402	3,75	114	335	4,50	15,21	12,7	18,6				0715/32053
103	123	205	372	3,05	123	310	3,65	14,08	12,4	18,1				0715/23062
122	146	244	313	3,60	146	261	4,30	11,85	11,8	17,3	0715/26059			
143	172	287	267	4,15	172	222	5,00	10,08	11,3	16,5	0715/29056			
167	201	334	229	4,80	201	191	5,75	8,65	10,8	15,8	0715/32053			
194	232	387	197	5,50	232	164	6,60	7,46	10,3	15,1	0715/35050			
224	269	447	171	6,25	269	142	7,50	6,46	9,9	14,5	0715/38047			
					37	1020	0,80	46,32	**	20,3	ASA 66A 70 113M4 ASA 66A IAK112 ARA 66A 70 113M4 ARA 66A IAK112	70 37 78 45	262 546 486 546	0615/12058
					43	897	0,90	40,73	**	20,3				0612/16068
41	49	82	929	0,90	49	775	1,05	35,14	3,0	20,3				0612/18066
47	57	94	811	1,00	57	676	1,20	30,67	8,7	20,2				0612B20064
56	67	112	680	1,20	67	566	1,45	25,72	11,7	19,5				0615/19051
65	78	129	591	1,40	78	493	1,65	22,36	12,2	18,9				0615/21049
74	89	148	518	1,55	89	431	1,90	19,58	12,6	18,3				0615/23047
89	107	178	429	1,90	107	357	2,25	16,22	12,0	17,4				0615/26044
107	128	213	358	2,25	128	298	2,70	13,55	11,4	16,6				0615/29041
116	139	232	330	1,95	139	275	2,30	12,48	11,1	16,2				0615/21049
132	159	264	289	2,20	159	241	2,60	10,93	10,7	15,6	0615/23047			
160	192	319	239	2,60	192	199	3,10	9,05	10,2	14,8	0615/26044			
191	229	382	200	3,05	229	167	3,65	7,56	9,7	14,1	0615/29041			
227	273	455	168	3,55	273	140	4,25	6,35	9,2	13,4	0615/32038			
					79	487	0,85	22,09	4,9	10,7	ASA 56A 70 113M4 ASA 56A IA112 ARA 56A 70 113M4 ARA 56A IA112	56 23 61 28	260 546 486 546	0512/20045
76	92	*153	501	0,80	92	417	1,00	18,94	6,6	10,5				0510/28054
90	107	*179	427	0,95	107	356	1,15	16,15	6,5	10,3				0510/31051
104	125	*209	367	1,10	125	306	1,35	13,86	6,3	10,0				0510/34048
122	146	*244	313	0,90	146	261	1,10	11,84	6,0	9,6				0512/20045
142	171	*285	268	1,05	171	224	1,25	10,15	5,8	9,3	0510/28054			
167	200	*334	229	1,20	200	191	1,45	8,66	5,6	9,0	0510/31051			
195	233	*389	196	1,40	233	164	1,65	7,43	5,4	8,7	0510/34048			
226	271	*452	169	1,60	271	141	1,90	6,40	5,2	8,4	0510/37045			

P_N = 5,5 kW / 7,5 HP

50 - 60 - 100 Hz 5,5 - 6,6 - 11 kW					60 Hz 5,5 kW			i	bei/at 50 Hz (F ₀ =0) (F _r =0)			m kg		ZT Code
n ₅₀ min ⁻¹	n ₆₀ min ⁻¹	n ₁₀₀ min ⁻¹	M ₂ Nm	f _B	n ₆₀ min ⁻¹	M ₂ Nm	f _B		F _{rN} kN	F _{aN} kN				
					2,9	16685	0,85	609,44	**	150,0	FSA 137C 70 133S4 FSA 137C IAK132 FRA 137C 70 133S4 FRA 137C IAK132	531 491 679 639	268 546 486 546	0815B12085
2,9	3,4	5,7	16435	0,90	3,4	13696	1,05	509,06	33,5	150,0				0817/12071
3,2	3,8	6,3	14864	0,95	3,8	12386	1,15	463,29	58,4	150,0				0817/13070
3,5	4,2	7,0	13534	1,05	4,2	11278	1,25	417,29	71,9	150,0				0812B20097
4,1	4,9	8,2	11459	1,25	4,9	9549	1,50	357,74	87,1	150,0				0815/19079
4,6	5,6	9,3	10150	1,40	5,6	8459	1,70	315,48	93,6	150,0				0815/21077
5,2	6,2	10	8905	1,60	6,2	7421	1,90	280,56	95,8	150,0				0815/23075
6,1	7,4	12	7498	1,90	7,4	6248	2,25	238,26	97,9	150,0				0815/26072
7,1	8,6	14	6349	2,25	8,6	5291	2,65	204,71	99,4	150,0				0815/29069
8,2	9,9	17	5418	2,60	9,9	4515	3,15	177,46	100,3	150,0				0815/32066
9,4	11	19	4638	3,05	11	3865	3,65	154,87	101,0	150,0	0815/35063			
					5,2	10179	0,80	337,46	**	66,0	FSA 131C 70 133S4 FSA 131C IAK132 FRA 131C 70 133S4 FRA 131C IAK132	355 315 435 395	268 546 486 546	0812B13104
					5,9	8933	0,90	298,79	**	66,0				0815B12085
5,8	7,0	12	9056	0,90	7,0	7547	1,10	249,58	30,4	66,0				0817/12071
6,4	7,7	13	8207	1,00	7,7	6839	1,20	227,13	45,6	66,0				0817/13070
7,1	8,6	14	7398	1,10	8,6	6165	1,30	204,58	46,5	66,0				0812B20097
8,3	10	17	6328	1,30	10	5274	1,55	175,39	45,5	66,0				0815/19079
9,4	11	19	5588	1,45	11	4656	1,75	154,67	44,5	66,0				0815/21077
11	13	21	4955	1,65	13	4129	1,95	137,55	43,5	65,0				0815/23075
13	15	25	4202	1,95	15	3502	2,30	116,81	42,1	62,7				0815/26072
15	18	29	3622	2,25	18	3019	2,70	100,36	40,7	60,6				0815/29069
17	20	34	3126	2,60	20	2605	3,10	87,00	39,3	58,5	0815/32066			
19	23	39	2736	2,95	23	2280	3,55	75,93	38,1	56,6	0815/35063			
					8,5	6165	0,85	207,08	**	46,5	FSA 111C 70 133S4 FSA 111C IAK132 FRA 111C 70 133S4 FRA 111C IAK132	246 206 307 267	268 546 486 546	0712B20083
8,4	10	17	6253	0,80	10	5211	1,00	173,33	**	46,5				0715/19066
9,6	12	19	5471	0,95	12	4559	1,10	152,07	**	46,5				0715/21064
11	13	22	4819	1,05	13	4016	1,25	134,51	**	46,5				0715/23062
13	16	26	4072	1,25	16	3393	1,50	113,23	28,5	46,5				0715/26059
					18	2978	1,35	99,06	35,8	46,5	FSA 111A 70 133S4 FSA 111A IAK132 FRA 111A 70 133S4 FRA 111A IAK132	236 196 297 257	264 546 486 546	1112B13153
17	20	33	3183	1,60	20	2653	1,90	88,38	36,8	46,5				1115B12126
20	24	39	2680	1,90	24	2233	2,25	74,35	35,4	46,5				1117/12106
22	26	43	2443	2,05	26	2036	2,50	67,98	34,7	46,1				1117/13105
24	29	48	2179	2,30	29	1816	2,80	60,60	33,7	44,8				1125/10072
27	32	54	1953	2,60	32	1627	3,10	54,33	32,8	43,6				1125/11071
30	36	60	1769	2,85	36	1474	3,40	49,10	32,0	42,5				1125/12070
					23	2292	1,25	76,36	17,7	36,8	ASA 86A 70 133S4 ASA 86A IAK132 ARA 86A 70 133S4 ARA 86A IAK132	146 106 176 136	262 546 486 546	0812B13104
22	26	43	2432	1,20	26	2026	1,40	67,61	24,0	36,8				0815B12085
26	31	52	2028	1,40	31	1690	1,70	56,48	24,1	35,5				0817/12071
28	34	57	1849	1,55	34	1541	1,85	51,40	23,7	34,8				0817/13070
32	38	63	1667	1,70	38	1390	2,05	46,30	23,2	34,0				0812B20097
37	44	74	1427	2,00	44	1189	2,40	39,69	22,4	32,8				0815/19079
42	50	83	1260	2,25	50	1050	2,70	35,00	21,7	31,8				0815/21077
47	56	94	1120	2,55	56	933	3,05	31,13	21,1	30,9				0815/23075
55	66	111	952	2,95	66	793	3,55	26,43	20,2	29,6				0815/26072
64	77	129	817	3,45	77	681	4,15	22,71	19,4	28,5				0815/29069
74	89	148	708	4,00	89	590	4,75	19,69	18,7	27,4				0815/32066
85	102	170	618	4,55	102	515	5,45	17,18	18,0	26,4				0815/35063
97	116	194	542	5,20	116	452	6,20	15,07	17,3	25,4				0815/38060

4

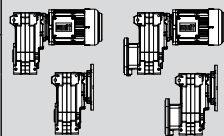
P_N = 5,5 kW / 7,5 HP



50 - 60 - 100 Hz 5,5 - 6,6 - 11 kW					60 Hz 5,5 kW			i	bei/at 50 Hz (F _a =0) (F _r =0)			m kg		ZT Code
n ₅₀ min ⁻¹	n ₆₀ min ⁻¹	n ₁₀₀ min ⁻¹	M ₂ Nm	f _B	n ₆₀ min ⁻¹	M ₂ Nm	f _B		F _{rN} kN	F _{aN} kN				
					28	1903	0,80	63,57	**	23,2	ASA 76A 70 133S4 ASA 76A IAK132 ARA 76A 70 133S4 ARA 76A IAK132	104 64 120 80	262 546 486 546	0712/13090
					31	1677	0,90	55,86	**	23,0				0715/12073
29	35	59	1799	0,85	35	1499	1,05	49,93	**	22,7				0712/16087
34	40	67	1559	1,00	40	1299	1,20	43,36	12,1	22,3				0712/18085
38	46	77	1371	1,10	46	1143	1,35	38,11	15,0	21,8				0712B20083
46	55	92	1147	1,35	55	956	1,60	31,90	14,5	21,2				0715/19066
52	63	104	1006	1,50	63	839	1,80	27,98	14,2	20,6				0715/21064
59	71	118	890	1,70	71	742	2,05	24,75	13,8	20,1				0715/23062
70	84	140	749	2,05	84	624	2,45	20,84	13,3	19,4				0715/26059
82	99	165	638	2,40	99	532	2,85	17,73	12,8	18,6				0715/29056
96	115	192	547	2,75	115	456	3,30	15,21	12,3	18,0				0715/32053
104	125	207	507	2,25	125	422	2,70	14,08	12,0	17,5	ASA 76S 70 133S4 ASA 76S IAK132 ARA 76S 70 133S4 ARA 76S IAK132	104 64 120 80	262 546 486 546	0715/23062
123	148	246	426	2,65	148	355	3,15	11,85	11,4	16,7				0715/26059
145	174	290	363	3,05	174	302	3,70	10,08	10,9	16,0				0715/29056
169	203	338	311	3,55	203	259	4,25	8,65	10,5	15,4				0715/32053
196	235	391	268	4,05	235	224	4,85	7,46	10,1	14,8				0715/35050
226	271	452	232	4,60	271	194	5,50	6,46	9,7	14,2				0715/38047
					50	1055	0,80	35,14	**	19,0	ASA 66A 70 133S4 ASA 66A IAK132 ARA 66A 70 133S4 ARA 66A IAK132	82 41 90 49	262 546 486 546	0612/18066
					57	920	0,90	30,67	**	18,7				0612B20064
57	68	114	925	0,90	68	771	1,05	25,72	3,4	18,2				0615/19051
65	78	131	804	1,00	78	670	1,20	22,36	8,9	17,8				0615/21049
75	90	149	704	1,15	90	587	1,40	19,58	11,4	17,3				0615/23047
90	108	180	584	1,40	108	486	1,65	16,22	11,5	16,6				0615/26044
102	122	203	516	1,25	122	430	1,50	14,36	11,0	16,0				0615/19051
117	140	234	449	1,40	140	374	1,70	12,48	10,7	15,5				0615/21049
134	160	267	393	1,60	160	328	1,90	10,93	10,3	15,0				0615/23047
161	194	323	326	1,90	194	271	2,30	9,05	9,9	14,4				0615/26044
193	232	386	272	2,25	232	227	2,70	7,56	9,4	13,7	0615/29041			
230	276	460	229	2,65	276	190	3,15	6,35	9,0	13,1	0615/32038			

$P_N = 7,5 \text{ kW} / 10 \text{ HP}$

50 - 60 - 100 Hz 7,5 - 9,0 - 15 kW					60 Hz 7,5 kW			i	bei/at 50 Hz ($F_a=0$) ($F_r=0$)			m kg		ZT Code
n_{50} min ⁻¹	n_{60} min ⁻¹	n_{100} min ⁻¹	M_2 Nm	f_B	n_{60} min ⁻¹	M_2 Nm	f_B		F_{rN} kN	F_{aN} kN				
4,1	4,9	8,1	15852	0,90	3,8	17615	0,80	463,29	**	150,0	FSA 137C 70 133M4 FSA 137C IAK132 FRA 137C 70 133M4 FRA 137C IAK132	541 491 689 639	268 546 486 546	0812B13104
					4,2	15570	0,90	417,29	**	150,0				0815B12085
					4,9	13210	1,10	357,74	44,7	150,0				0817/12071
					5,5	11726	1,20	315,48	66,9	150,0				0817/13070
					6,2	10309	1,40	280,56	81,0	150,0				0812B20097
					7,3	8716	1,65	238,26	92,7	150,0				0815/19079
					8,5	7412	1,90	204,71	95,8	150,0				0815/21077
					9,8	6352	2,25	177,46	97,8	150,0				0815/23075
					11	5472	2,60	154,87	99,1	150,0				0815/26072
					13	4738	3,00	135,85	100,1	150,0				0815/29069
13	15	25	4691	3,00	15	3909	3,60	114,72	101,0	150,0			0815/32066	
8,6	10	17	8328	1,70	10	6940	2,05	169,39	96,7	150,0	FSA 137A 70 133M4 FSA 137A IAK132 FRA 137A 70 133M4 FRA 137A IAK132	515 465 663 613	264 546 486 546	0815/35063
					11	6350	2,25	155,12	97,8	150,0				0815/38060
					13	5685	2,50	138,74	98,8	150,0				0815/29069
					14	5101	2,75	124,66	99,6	150,0				0815/32066
					16	4627	3,05	112,93	100,2	150,0				0815/35063
7,1	8,5	14	10088	0,80	7,0	10291	0,80	249,58	**	64,0	FSA 131C 70 133M4 FSA 131C IAK132 FRA 131C 70 133M4 FRA 131C IAK132	365 315 445 395	268 546 486 546	0815/38060
					7,7	9326	0,90	227,13	**	63,8				0815/42056
					8,5	8407	1,00	204,58	**	63,4				0815/46052
					10	7191	1,15	175,39	39,0	62,5				0712/18085
					11	6350	1,30	154,67	40,7	61,6				0712B20083
					13	5631	1,45	137,55	40,2	60,6				0715/19066
					15	4775	1,70	116,81	39,3	59,0				0715/21064
					17	4116	1,95	100,36	38,3	57,4				0715/23062
					20	3574	2,25	87,00	37,4	55,8				0715/26059
					18	21	35	4093	1,80	21				3411
19	23	38	3750	2,15	23	3125	2,60	76,05	36,4	54,2	0715/32053			
21	26	43	3347	2,40	26	2789	2,90	68,02	35,5	52,8	0715/23062			
24	29	48	3009	2,70	29	2508	3,20	61,12	34,6	51,6	0715/26059			
26	32	53	2723	2,95	32	2269	3,55	55,36	33,8	50,3	0715/29056			
11	13	22	6632	0,80	12	6217	0,85	152,07	**	46,5	FSA 111C 70 133M4 FSA 111C IAK132 FRA 111C 70 133M4 FRA 111C IAK132	256 206 317 267	268 546 486 546	0715/32053
					13	5527	0,95	134,51	**	46,5				0715/35050
					15	4663	1,10	113,23	**	46,5				0715/38047
					18	3953	1,30	96,36	9,2	46,5				0715/42043
15	18	29	4872	0,85	18	4060	1,00	99,06	**	46,5	FSA 111A 70 133M4 FSA 111A IAK132 FRA 111A 70 133M4 FRA 111A IAK132	246 196 307 257	264 546 486 546	0615/19051
17	20	33	4341	1,15	20	3617	1,40	88,38	23,1	45,8				0615/21049
20	24	39	3654	1,40	24	3045	1,65	74,35	33,4	44,5				0615/23047
21	26	43	3347	1,50	26	2789	1,80	67,98	32,8	43,7				0615/26044
24	29	48	2984	1,70	29	2487	2,05	60,60	32,1	42,7				0615/19051
27	32	54	2673	1,90	32	2227	2,25	54,33	31,4	41,7				0615/21049
30	36	59	2420	2,10	36	2016	2,50	49,10	30,7	40,8				0615/23047
36	43	71	2012	2,50	43	1677	3,00	40,88	29,4	39,1				0615/26044
42	50	84	1709	2,95	50	1425	3,55	34,72	28,2	37,6				0615/29041

4

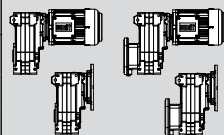
P_N = 7,5 kW / 10 HP



50 - 60 - 100 Hz 7,5 - 9,0 - 15 kW					60 Hz 7,5 kW			i	bei/at 50 Hz (F _a =0) (F _r =0)			m kg		ZT Code
n ₅₀ min ⁻¹	n ₆₀ min ⁻¹	n ₁₀₀ min ⁻¹	M ₂ Nm	f _B	n ₆₀ min ⁻¹	M ₂ Nm	f _B		F _{rN} kN	F _{aN} kN				
					23	3125	0,90	76,36	**	34,2				0812B13104
22	26	43	3331	0,85	26	2776	1,05	67,61	**	33,8				0815B12085
26	31	52	2776	1,05	31	2313	1,25	56,48	17,0	33,0				0817/12071
28	34	57	2531	1,15	34	2109	1,35	51,40	22,1	32,6				0817/13070
31	38	63	2281	1,25	38	1901	1,50	46,30	21,7	32,0				0812B20097
37	44	73	1952	1,45	44	1626	1,75	39,69	21,1	31,1				0815/19079
42	50	83	1722	1,65	50	1435	2,00	35,00	20,6	30,3				0815/21077
47	56	94	1534	1,85	56	1278	2,20	31,13	20,2	29,6				0815/23075
55	66	110	1302	2,20	66	1085	2,60	26,43	19,4	28,5		156	262	0815/26072
64	77	128	1117	2,55	77	931	3,05	22,71	18,8	27,5		106	546	0815/29069
74	89	148	969	2,90	89	808	3,50	19,69	18,1	26,5		186	486	0815/32066
85	102	169	846	3,35	102	705	4,00	17,18	17,5	25,6		136	546	0815/35063
97	116	193	742	3,80	116	619	4,55	15,07	16,9	24,8				0815/38060
105	126	210	682	3,35	126	568	4,05	13,86	16,4	24,1				0815/29069
121	145	242	591	3,85	145	493	4,60	12,01	15,8	23,2		156	262	0815/32066
139	167	278	516	4,25	167	430	5,10	10,48	15,2	22,3		106	546	0815/35063
158	190	317	453	4,65	190	377	5,55	9,20	14,7	21,5		186	486	0815/38060
187	225	375	382	5,15	225	319	6,20	7,77	14,0	20,5		136	546	0815/42056
221	265	442	324	5,70	265	270	6,80	6,58	13,3	19,5				0815/46052
					40	1776	0,85	43,36	**	20,0				0712/18085
38	46	76	1875	0,85	46	1563	1,00	38,11	**	19,8				0712B20083
46	55	91	1571	1,00	55	1309	1,15	31,90	11,8	19,5		114	262	0715/19066
52	62	104	1377	1,10	62	1148	1,35	27,98	13,1	19,2		64	546	0715/21064
59	71	118	1218	1,25	71	1015	1,50	24,75	12,9	18,8		130	486	0715/23062
70	84	140	1026	1,50	84	855	1,80	20,84	12,5	18,3		80	546	0715/26059
82	99	164	872	1,75	99	727	2,10	17,73	12,1	17,7				0715/29056
96	115	191	748	2,05	115	624	2,45	15,21	11,8	17,2				0715/32053
103	124	207	693	1,65	124	577	2,00	14,08	11,4	16,7				0715/23062
123	147	246	583	1,95	147	486	2,30	11,85	11,0	16,1		114	262	0715/26059
144	173	289	496	2,25	173	414	2,70	10,08	10,6	15,5		64	546	0715/29056
168	202	336	426	2,60	202	355	3,10	8,65	10,2	14,9		130	486	0715/32053
195	234	390	367	2,95	234	306	3,55	7,46	9,8	14,4		80	546	0715/35050
225	270	451	318	3,40	270	265	4,05	6,46	9,4	13,8				0715/38047
272	327	544	263	3,90	327	219	4,65	5,35	9,0	13,1				0715/42043
					68	1055	0,80	25,72	**	16,6				0615/19051
					78	917	0,90	22,36	**	16,3		92	262	0615/19051
74	89	*149	964	0,85	89	803	1,00	19,58	**	16,1		41	546	0615/21049
90	108	*179	798	1,05	108	665	1,25	16,22	9,1	15,6		100	486	0615/23047
101	122	*203	707	0,90	122	589	1,1	14,36	10,4	15,1		49	546	0615/26044
117	140	*233	614	1,05	140	512	1,25	12,48	10,1	14,7				0615/19051
133	160	*266	538	1,20	160	448	1,40	10,93	9,9	14,3		92	262	0615/21049
161	193	*321	446	1,40	193	371	1,70	9,05	9,5	13,8		41	546	0615/23047
192	231	*385	372	1,65	231	310	2,00	7,56	9,1	13,2		100	486	0615/26044
229	275	*458	313	1,95	275	261	2,30	6,35	8,7	12,7		49	546	0615/29041
														0615/32038

P_N = 11 kW / 15 HP

50 - 60 - 100 Hz 11 - 13 - 22 kW					60 Hz 11 kW			i	bei/at 50 Hz (F _a =0) (F _r =0)			m kg		ZT Code
n ₅₀ min ⁻¹	n ₆₀ min ⁻¹	n ₁₀₀ min ⁻¹	M ₂ Nm	f _B	n ₆₀ min ⁻¹	M ₂ Nm	f _B		F _{rN} kN	F _{aN} kN				
					5,6	17411	0,85	315,48	**	150,0	FSA 137C 70 161M4 FSA 137C IAK160 FRA 137C 70 161M4 FRA 137C IAK160	574	268	0815/21077
5,2	6,2	10	18406	0,80	6,2	15339	0,95	280,56	**	150,0		500	546	0815/23075
6,1	7,4	12	15627	0,90	7,4	13022	1,10	238,26	48,2	150,0		722	486	0815/26072
7,1	8,6	14	13343	1,05	8,6	11119	1,30	204,71	73,5	150,0		648	546	0815/29069
8,2	9,9	17	11459	1,25	9,9	9549	1,50	177,46	87,1	150,0			0815/32066	
8,6	10	17	12215	1,15	10	10179	1,40	169,39	82,1	150,0	FSA 137A 70 161M4 FSA 137A IAK160 FRA 137A 70 161M4 FRA 137A IAK160	548	264	1317/12126
9,4	11	19	11176	1,30	11	9313	1,55	155,12	88,8	150,0		474	546	1317/13125
11	13	21	10005	1,40	13	8337	1,70	138,74	93,8	150,0		696	486	1325/10086
12	14	23	8979	1,60	14	7482	1,90	124,66	95,7	150,0		622	546	1325/11085
13	16	26	8143	1,75	16	6786	2,10	112,93	97,0	150,0				1325/12084
16	19	31	6777	2,10	19	5648	2,50	94,49	98,9	150,0				1325/14082
18	22	36	5804	2,45	22	4837	2,90	80,66	100,0	148,3				1325/16080
21	25	42	5026	2,80	25	4189	3,35	69,91	100,7	143,7				1325/18078
					10	10547	0,80	175,39	**	52,6	FSA 131C 70 161M4 FSA 131C IAK160 FRA 131C 70 161M4 FRA 131C IAK160	398	268	0815/19079
11	13	21	9910	0,85	11	9313	0,90	154,67	**	52,8		324	546	0815/21077
13	15	25	8404	1,00	13	8259	1,00	137,55	**	52,8		478	486	0815/23075
15	18	29	7245	1,15	15	7003	1,15	116,81	34,1	52,4		404	546	0815/26072
17	20	34	6253	1,30	17	6037	1,35	100,36	34,0	51,7			0815/29069	
12	14	23	8979	0,85	20	5211	1,55	87,00	33,6	50,8	FSA 131A 70 161L6 FSA 131A IAK160 FRA 131A 70 161L6 FRA 131A IAK160	374	264	1317/12126
13	15	26	8207	1,00	14	7482	1,00	83,05	32,2	52,6		298	546	1317/13125
14	17	29	7346	1,10	15	6839	1,20	76,05	34,1	52,3		454	486	1325/10086
16	19	32	6607	1,25	17	6122	1,35	68,02	34,0	51,8		378	546	1325/11085
18	21	35	5969	1,25	19	5506	1,50	61,12	33,8	51,2	FSA 131A 70 161M4 FSA 131A IAK160 FRA 131A 70 161M4 FRA 131A IAK160	372	264	1317/12126
19	23	38	5471	1,50	21	4974	1,50	83,05	33,4	50,5		298	546	1317/13125
22	26	43	4886	1,65	23	4559	1,80	76,05	33,1	49,9		452	486	1325/10086
24	29	48	4395	1,85	26	4072	2,00	68,02	32,6	49,0		378	546	1325/11085
26	32	53	3979	2,05	29	3663	2,20	61,12	32,1	48,1				1325/12084
32	38	63	3335	2,40	32	3316	2,45	55,36	31,5	47,2				1325/14082
37	44	74	2847	2,85	38	2779	2,90	46,33	30,5	45,5				1325/16080
37	44	74	2847	2,85	44	2372	3,40	39,55	29,5	43,9				1325/16080
17	20	33	6367	0,80	20	5306	0,95	88,38	**	40,4	FSA 111A 70 161M4 FSA 111A IAK160 FRA 111A 70 161M4 FRA 111A IAK160	279	264	1115B12126
20	24	39	5360	0,95	24	4466	1,15	74,35	**	39,9		205	546	1117/12106
22	26	43	4886	1,05	26	4072	1,25	67,98	**	39,5		340	486	1117/13105
24	29	48	4359	1,15	29	3632	1,40	60,60	22,7	38,9		266	546	1125/10072
27	32	54	3905	1,30	32	3254	1,55	54,33	28,7	38,3				1125/11071
30	36	60	3537	1,45	36	2948	1,70	49,10	28,3	37,8				1125/12070
36	43	71	2943	1,70	43	2452	2,05	40,88	27,4	36,5				1125/14068
42	51	84	2495	2,05	51	2079	2,45	34,72	26,6	35,4				1125/16066
49	59	98	2153	2,35	59	1794	2,80	29,93	25,8	34,3				1125/18064
56	67	112	1876	2,70	67	1563	3,20	26,09	25,0	33,2				1125/20062
60	72	121	1742	2,00	72	1452	2,40	24,21	24,1	32,2	FSA 111S 70 161M4 FSA 111S IAK160 FRA 111S 70 161M4 FRA 111S IAK160	279	264	1125/11071
67	80	134	1575	2,45	80	1312	2,90	21,88	23,6	31,5		205	546	1125/12070
80	96	160	1310	3,30	96	1092	3,95	18,21	22,6	30,1		340	486	1125/14068
94	113	189	1113	4,05	113	927	4,85	15,47	21,6	28,9		266	546	1125/16066
110	131	219	959	4,65	131	799	5,55	13,33	20,8	27,8				1125/18064
126	151	251	836	5,25	151	697	6,30	11,63	20,1	26,8				1125/20062
143	171	286	736	5,85	171	613	7,00	10,23	19,4	25,9			1125/22060	

4

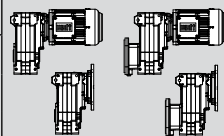
P_N = 11 kW / 15 HP



50 - 60 - 100 Hz 11 - 13 - 22 kW					60 Hz 11 kW			i	bei/at 50 Hz (F _a =0) (F _r =0)			m kg		ZT Code
n ₅₀ min ⁻¹	n ₆₀ min ⁻¹	n ₁₀₀ min ⁻¹	M ₂ Nm	f _B	n ₆₀ min ⁻¹	M ₂ Nm	f _B		F _{rN} kN	F _{aN} kN				
					31	3380	0,85	56,48	**	28,7	ASA 86A 70 161M4 ASA 86A IAK160 ARA 86A 70 161M4 ARA 86A IAK160	189 115 219 145	262 546 486 546	0817/12071
28	34	57	3699	0,80	34	3082	0,95	51,40	**	28,6				0817/13070
32	38	63	3335	0,85	38	2779	1,05	46,30	**	28,4				0812B20097
37	44	74	2855	1,00	44	2379	1,20	39,69	14,8	28,0				0815/19079
42	50	83	2519	1,15	50	2099	1,35	35,00	18,6	27,6				0815/21077
47	56	94	2240	1,30	56	1867	1,55	31,13	18,4	27,2				0815/23075
55	66	111	1903	1,50	66	1586	1,80	26,43	18,0	26,5				0815/26072
64	77	129	1634	1,75	77	1361	2,10	22,71	17,5	25,7				0815/29069
74	89	148	1416	2,00	89	1180	2,40	19,69	17,0	25,0				0815/32066
85	102	170	1236	2,30	102	1030	2,75	17,18	16,6	24,3				0815/35063
97	116	194	1084	2,60	116	903	3,10	15,07	16,1	23,6	0815/38060			
105	126	211	997	2,30	126	831	2,75	13,86	15,6	23,0	ASA 86S 70 161M4 ASA 86S IAK160 ARA 86S 70 161M4 ARA 86S IAK160	189 115 219 145	262 546 486 546	0815/29069
122	146	243	864	2,65	146	720	3,15	12,01	15,1	22,2				0815/32066
139	167	279	754	2,90	167	628	3,50	10,48	14,6	21,5				0815/35063
159	191	318	662	3,20	191	551	3,80	9,20	14,2	20,8				0815/38060
188	226	376	559	3,55	226	466	4,25	7,77	13,5	19,9				0815/42056
222	266	444	474	3,90	266	395	4,65	6,58	13,0	19,0				0815/46052
					55	1911	0,80	31,90	**	16,5	ASA 76A 70 161M4 ASA 76A IAK160 ARA 76A 70 161M4 ARA 76A IAK160	147 73 163 89	262 546 486 546	0715/19066
					63	1677	0,90	27,98	**	16,5				0715/21064
59	71	*118	1781	0,85	71	1484	1,05	24,75	1,8	16,5				0715/23062
70	84	*140	1499	1,05	84	1249	1,25	20,84	11,2	16,3				0715/26059
82	99	*165	1276	1,20	99	1064	1,45	17,73	11,0	16,0				0715/29056
96	115	*192	1094	1,40	115	912	1,65	15,21	10,8	15,7				0715/32053
111	134	*223	944	1,60	134	787	1,95	13,12	10,5	15,4				0715/35050
123	148	*246	853	1,35	148	711	1,60	11,85	10,2	14,9				0715/26059
145	174	*290	725	1,55	174	605	1,85	10,08	9,9	14,5				0715/29056
169	203	*338	622	1,80	203	519	2,15	8,65	9,6	14,1				0715/32053
196	235	*391	537	2,05	235	447	2,45	7,46	9,3	13,6	0715/35050			
226	271	*452	465	2,30	271	387	2,75	6,46	9,0	13,2	0715/38047			
273	328	*546	385	2,65	328	321	3,20	5,35	8,6	12,6	0715/42043			

P_N = 15 kW / 20 HP

50 - 60 - 100 Hz 15 - 18 - 30 kW					60 Hz 15 kW			i	bei/at 50 Hz (F _a =0) (F _r =0)			m kg		ZT Code
n ₅₀ min ⁻¹	n ₆₀ min ⁻¹	n ₁₀₀ min ⁻¹	M ₂ Nm	f _B	n ₆₀ min ⁻¹	M ₂ Nm	f _B		F _{rN} kN	F _{aN} kN				
					7,4	17904	0,80	238,26	**	150,0				0815/26072
7,1	8,6	14	18383	0,80	8,6	15319	0,95	204,71	**	150,0	FSA 137C 70 161L4	595	268	0815/29069
8,2	9,9	17	15852	0,90	9,9	13210	1,10	177,46	44,7	150,0	FSA 137C IAK160	500	546	0815/32066
9,4	11	19	13743	1,05	11	11453	1,25	154,87	70,0	150,0	FRA 137C 70 161L4	743	486	0815/35063
8,6	10	17	16657	0,85	10	13881	1,05	169,39	27,9	150,0	FRA 137C IAK160	648	546	1317/12126
9,4	11	19	15239	0,95	11	12699	1,15	155,12	53,7	150,0				1317/13125
11	13	21	13643	1,05	13	11369	1,25	138,74	70,9	150,0				1325/10086
12	14	23	12244	1,15	14	10203	1,40	124,66	81,9	150,0				1325/11085
13	16	26	11105	1,30	16	9254	1,55	112,93	89,2	149,9	FSA 137A 70 161L4	569	264	1325/12084
16	19	31	9242	1,55	19	7702	1,85	94,49	95,2	145,7	FSA 137A IAK160	474	546	1325/14082
18	22	36	7914	1,80	22	6595	2,15	80,66	97,3	141,9	FRA 137A 70 161L4	717	486	1325/16080
21	25	42	6854	2,05	25	5712	2,50	69,91	98,8	138,1	FRA 137A IAK160	622	546	1325/18078
24	29	48	6019	2,35	29	5016	2,80	61,30	96,7	134,6				1325/20076
27	32	54	5325	2,65	32	4438	3,20	54,26	94,3	131,2				1325/22074
30	36	60	4743	3,00	36	3953	3,55	48,40	92,0	127,9				1325/24072
					15	9550	0,85	116,81	**	44,8	FSA 131C 70 161L4	419	268	0815/26072
15	18	29	9879	0,85	18	8233	1,00	100,36	**	45,2	FSA 131C IAK160	324	546	0815/29069
17	20	34	8527	0,95	20	7106	1,15	87,00	29,1	45,2	FRA 131C 70 161L4	499	486	0815/32066
19	23	39	7461	1,10	23	6217	1,30	75,93	29,2	45,0	FRA 131C IAK160	404	546	0815/35063
18	21	35	8139	0,95	21	6783	1,10	83,05	29,2	45,1				1317/12126
19	23	38	7461	1,10	23	6217	1,30	76,05	29,2	45,0				1317/13125
22	26	43	6663	1,25	26	5552	1,45	68,02	29,2	44,6	FSA 131A 70 161L4	393	264	1325/10086
24	29	48	5994	1,35	29	4995	1,65	61,12	29,0	44,1	FSA 131A IAK160	298	546	1325/11085
26	32	53	5426	1,50	32	4522	1,80	55,36	28,8	43,6	FRA 131A 70 161L4	473	486	1325/12084
32	38	63	4548	1,80	38	3790	2,15	46,33	28,2	42,5	FRA 131A IAK160	378	546	1325/14082
37	44	74	3882	2,10	44	3235	2,50	39,55	27,6	41,4				1325/16080
43	51	85	3363	2,40	51	2802	2,90	34,27	26,9	40,3				1325/18078
49	58	97	2948	2,75	58	2456	3,30	30,06	26,3	39,2				1325/20076
52	62	103	2782	1,85	62	2318	2,20	28,33	25,3	38,1				1325/11085
57	68	114	2518	2,25	68	2098	2,70	25,67	24,9	37,3	FSA 131S 70 161L4	293	264	1325/12084
68	82	136	2107	3,10	82	1756	3,75	21,48	24,0	35,9	FSA 131S IAK160	298	546	1325/14082
80	96	159	1800	3,80	96	1500	4,55	18,33	23,1	34,6	FRA 131S 70 161L4	473	486	1325/16080
92	110	184	1559	4,40	110	1299	5,30	15,89	22,4	33,4	FRA 131S IAK160	378	546	1325/18078
105	126	210	1367	5,00	126	1139	6,00	13,93	21,7	32,3				1325/20076
118	142	237	1210	5,60	142	1008	6,70	12,33	21,0	31,3				1325/22074
					24	6091	0,85	74,35	**	34,6				1117/12106
22	26	43	6663	0,80	26	5552	0,95	67,98	**	34,7				1117/13105
24	29	48	5944	0,85	29	4953	1,05	60,60	**	34,7	FSA 111A 70 161L4	300	264	1125/10072
27	32	54	5325	0,95	32	4438	1,15	54,33	**	34,5	FSA 111A IAK160	205	546	1125/11071
30	36	60	4823	1,05	36	4019	1,25	49,10	**	34,3	FRA 111A 70 161L4	361	486	1125/12070
36	43	71	4013	1,25	43	3344	1,50	40,88	25,1	33,7	FRA 111A IAK160	266	546	1125/14068
42	51	84	3403	1,50	51	2836	1,80	34,72	24,6	32,9				1125/16066
49	59	98	2935	1,75	59	2446	2,05	29,93	24,1	32,2				1125/18064
56	67	112	2558	2,00	67	2132	2,35	26,09	23,6	31,4				1125/20062
64	76	127	2252	2,25	76	1877	2,70	22,96	23,0	30,6				1125/22060
72	86	144	1995	2,55	86	1663	3,05	20,34	22,4	29,9				1125/24058
81	97	161	1780	2,85	97	1483	3,40	18,13	21,9	29,1				1125/26056
90	108	180	1593	3,15	108	1328	3,80	16,23	21,4	28,4				1125/28054
94	113	189	1517	2,95	113	1265	3,55	15,47	20,7	27,7				1125/16066
110	131	219	1308	3,40	131	1090	4,10	13,33	20,0	26,7	FSA 111S 70 161L4	300	264	1125/18064
126	151	251	1141	3,85	151	950	4,60	11,63	19,4	25,9	FSA 111S IAK160	205	546	1125/20062
143	171	286	1003	4,30	171	836	5,15	10,23	18,8	25,1	FRA 111S 70 161L4	361	486	1125/22060
161	193	322	889	4,70	193	741	5,65	9,06	18,2	24,3	FRA 111S IAK160	266	546	1125/24058

4

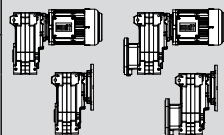
P_N = 15 kW / 20 HP



50 - 60 - 100 Hz 15 - 18 - 30 kW					60 Hz 15 kW			i	bei/at 50 Hz (F _a =0) (F _r =0)			m kg		ZT Code
n ₅₀ min ⁻¹	n ₆₀ min ⁻¹	n ₁₀₀ min ⁻¹	M ₂ Nm	f _B	n ₆₀ min ⁻¹	M ₂ Nm	f _B		F _{rN} kN	F _{aN} kN				
					44	3244	0,90	39,69	**	24,6				0815/19079
42	50	83	3435	0,85	50	2863	1,00	35,00	**	24,6				0815/21077
47	56	94	3054	0,95	56	2545	1,15	31,13	5,5	24,5	ASA 86A 70 161L4 ASA 86A IAK160 ARA 86A 70 161L4 ARA 86A IAK160	210	262	0815/23075
55	66	111	2595	1,10	66	2163	1,30	26,43	16,2	24,2		155	546	0815/26072
64	77	129	2228	1,30	77	1857	1,55	22,71	16,0	23,8		240	486	0815/29069
74	89	148	1931	1,50	89	1609	1,75	19,69	15,8	23,3		145	546	0815/32066
85	102	170	1685	1,70	102	1404	2,00	17,18	15,5	22,8				0815/35063
97	116	194	1478	1,90	116	1232	2,30	15,07	15,1	22,3				0815/38060
105	126	211	1359	1,70	126	1133	2,05	13,86	14,7	21,7				0815/29069
122	146	243	1178	1,95	146	982	2,35	12,01	14,3	21,1	ASA 86S 70 161L4 ASA 86S IAK160 ARA 86S 70 161L4 ARA 86S IAK160	210	262	0815/32066
139	167	279	1028	2,15	167	857	2,60	10,48	14,0	20,5		115	546	0815/35063
159	191	318	902	2,35	191	752	2,80	9,20	13,6	19,9		240	486	0815/38060
188	226	376	762	2,60	226	635	3,10	7,77	13,0	19,2		145	546	0815/42056
222	266	444	646	2,85	266	538	3,45	6,58	12,5	18,4				0815/46052
					84	1703	0,90	20,84	**	14,1				0715/26059
82	99	*165	1741	0,90	99	1450	1,05	17,73	5,5	14,2	ASA 76A 70 161L4 ASA 76A IAK160 ARA 76A 70 161L4 ARA 76A IAK160	168	262	0715/29056
96	115	*192	1492	1,05	115	1243	1,25	15,21	9,6	14,1		73	546	0715/32053
111	134	*223	1287	1,20	134	1073	1,40	13,12	9,6	14,0		184	486	0715/35050
129	154	*257	1114	1,35	154	928	1,65	11,36	9,4	13,8		89	546	0715/38047
155	186	*311	922	1,65	186	769	2,00	9,40	9,2	13,4				0715/42043
169	203	*338	849	1,30	203	707	1,55	8,65	8,9	13,1	ASA 76S 70 161L4 ASA 76S IAK160 ARA 76S 70 161L4 ARA 76S IAK160	168	262	0715/32053
196	235	*391	732	1,50	235	610	1,80	7,46	8,7	12,8		73	546	0715/35050
226	271	*452	634	1,70	271	528	2,05	6,46	8,5	12,5		184	486	0715/38047
273	328	*546	525	1,95	328	437	2,35	5,35	8,2	12,0		89	546	0715/42043

P_N = 18,5 kW / 25 HP

50 - 60 - 100 Hz 18,5 - 22 - 37 kW					60 Hz 18,5 kW			i	bei/at 50 Hz (F ₀ =0) (F _r =0)			m kg		ZT Code			
n ₅₀ min ⁻¹	n ₆₀ min ⁻¹	n ₁₀₀ min ⁻¹	M ₂ Nm	f _B	n ₆₀ min ⁻¹	M ₂ Nm	f _B		F _{rN} kN	F _{aN} kN							
					10	17321	0,85	169,39	**	144,7	FSA 137A 7B 180M4 FSA 137A IAK180 FRA 137A 7B 180M4 FRA 137A IAK180	618 474 766 622	264 546 486 546	1317/12126			
					11	15831	0,90	155,12	**	144,6				1317/13125			
10	13	21	16988	0,85	13	14157	1,00	138,74	16,1	144,1				1325/10086			
12	14	23	15231	0,95	14	12692	1,15	124,66	53,8	143,2				1325/11085			
13	15	26	13803	1,05	15	11502	1,25	112,93	69,5	142,0				1325/12084			
15	18	31	11623	1,25	18	9686	1,45	94,49	86,0	139,4				1325/14082			
18	21	36	9870	1,45	21	8225	1,75	80,66	94,1	136,4				1325/16080			
21	25	41	8576	1,65	25	7147	2,00	69,91	95,6	133,5				1325/18078			
24	28	47	7518	1,90	28	6265	2,25	61,30	93,6	130,6				1325/20076			
27	32	53	6667	2,10	32	5556	2,55	54,26	91,7	127,7				1325/22074			
30	36	60	5929	2,40	36	4941	2,85	48,40	89,7	124,9	1325/24072						
33	40	66	5322	2,65	40	4435	3,20	43,43	87,8	122,2	1325/26070						
37	44	74	4801	2,95	44	4001	3,50	39,18	85,9	119,6	1325/28068						
					21	8510	0,90	83,05	**	40,4	FSA 131A 7B 180M4 FSA 131A IAK180 FRA 131A 7B 180M4 FRA 131A IAK180	442 298 522 378	264 546 486 546	1317/12126			
19	23	38	9348	0,90	23	7790	1,05	76,05	22,5	40,6				1317/13125			
21	25	42	8334	1,00	25	6945	1,20	68,02	26,0	40,7				1325/10086			
24	28	47	7486	1,10	28	6239	1,30	61,12	26,2	40,7				1325/11085			
26	31	52	6795	1,20	31	5663	1,45	55,36	26,3	40,5				1325/12084			
31	37	62	5681	1,45	37	4734	1,70	46,33	26,2	39,9				1325/14082			
36	44	73	4854	1,65	44	4045	2,00	39,55	25,9	39,2				1325/16080			
42	50	84	4207	1,95	50	3505	2,30	34,27	25,5	38,4				1325/18078			
48	58	96	3688	2,20	58	3074	2,65	30,06	25,1	37,6				1325/20076			
54	65	108	3266	2,45	65	2721	2,95	26,60	24,6	36,8				1325/22074			
61	73	121	2911	2,75	73	2426	3,30	23,73	24,1	36,0	1325/24072						
					81	2194	3,00	21,48	23,0	34,6	FSA 131S 7B 180M4 FSA 131S IAK180 FRA 131S 7B 180M4 FRA 131S IAK180	442 298 522 378	264 546 486 546	1325/14082			
79	94	157	2251	3,05	94	1876	3,65	18,33	22,4	33,6				1325/16080			
91	109	181	1950	3,55	109	1625	4,25	15,89	21,7	32,5				1325/18078			
103	124	207	1710	4,00	124	1425	4,80	13,93	21,1	31,5				1325/20076			
117	140	234	1513	4,50	140	1261	5,40	12,33	20,5	30,6				1325/22074			
131	157	262	1350	4,95	157	1125	5,90	11,00	20,0	29,8				1325/24072			
146	175	292	1211	5,30	175	1009	6,40	9,87	19,4	29,0				1325/26070			
162	194	323	1093	5,30	194	911	6,40	8,91	18,9	28,2				1325/28068			
					29	6186	0,85	60,60	**	30,9				FSA 111A 7B 180M4 FSA 111A IAK180 FRA 111A 7B 180M4 FRA 111A IAK180	349 205 410 266	264 546 486 546	1125/10072
					32	5556	0,90	54,33	**	31,1							1125/11071
29	35	59	6030	0,85	35	5025	1,00	49,10	**	31,2	1125/12070						
35	42	70	5019	1,00	42	4183	1,20	40,88	**	31,1	1125/14068						
42	50	83	4257	1,20	50	3548	1,45	34,72	22,9	30,8	1125/16066						
48	58	96	3673	1,40	58	3061	1,65	29,93	22,7	30,4	1125/18064						
55	66	110	3201	1,60	66	2667	1,90	26,09	22,3	29,8	1125/20062						
63	75	126	2818	1,80	75	2348	2,15	22,96	21,9	29,3	1125/22060						
71	85	142	2495	2,05	85	2080	2,45	20,34	21,5	28,7	1125/24058						
79	95	159	2225	2,25	95	1854	2,70	18,13	21,1	28,1	1125/26056						
89	107	177	1992	2,55	107	1660	3,05	16,23	20,6	27,5	1125/28054						
					130	1363	3,25	13,33	19,4	25,9	FSA 111S 7B 180M4 FSA 111S IAK180 FRA 111S 7B 180M4 FRA 111S IAK180	349 205 410 266	264 546 486 546	1125/18064			
124	149	248	1426	3,10	149	1188	3,70	11,63	18,8	25,2				1125/20062			
141	169	282	1255	3,45	169	1046	4,10	10,23	18,3	24,4				1125/22060			
159	191	318	1112	3,75	191	927	4,50	9,06	17,8	23,8				1125/24058			
178	214	357	991	4,15	214	826	4,95	8,08	17,3	23,1				1125/26056			
199	239	398	887	4,45	239	739	5,35	7,23	16,8	22,5				1125/28054			
233	280	467	757	5,00	280	631	6,00	6,17	16,2	21,6				1125/31051			
272	326	544	650	5,50	326	541	6,55	5,29	15,5	20,7				1125/34048			
316	379	632	560	5,95	379	466	7,15	4,56	14,9	19,9				1125/37045			

4

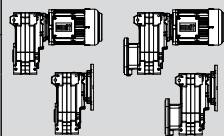
$P_N = 18,5 \text{ kW} / 25 \text{ HP}$

50 - 60 - 100 Hz 18,5 - 22 - 37 kW					60 Hz 18,5 kW			i	bei/at 50 Hz ($F_a=0$) ($F_r=0$)			m kg		ZT Code
n_{50} min ⁻¹	n_{60} min ⁻¹	n_{100} min ⁻¹	M_2 Nm	f_B	n_{60} min ⁻¹	M_2 Nm	f_B		F_{rN} kN	F_{aN} kN				
					49	3582	0,80	35,00	**	21,9	ASA 86A 7B 180M4 ASA 86A IAK180 ARA 86A 7B 180M4 ARA 86A IAK180	259 115 289 145	262 546 486 546	0815/21077
					56	3180	0,90	31,13	**	22,1				0815/23075
55	65	*109	3242	0,90	65	2701	1,05	26,43	**	22,2				0815/26072
63	76	*127	2787	1,05	76	2322	1,25	22,71	14,7	22,0				0815/29069
73	88	*146	2417	1,20	88	2014	1,40	19,69	14,6	21,8				0815/32066
84	101	*168	2108	1,35	101	1757	1,60	17,18	14,5	21,5				0815/35063
96	115	*191	1850	1,55	115	1542	1,85	15,07	14,3	21,2				0815/38060
113	136	*226	1562	1,80	136	1302	2,20	12,73	14,0	20,6				0815/42056
134	160	*267	1323	2,15	160	1103	2,55	10,79	13,6	20,0				0815/46052
137	165	*275	1286	1,75	165	1072	2,05	10,48	13,4	19,7				ASA 86S 7B 180M4 ASA 86S IAK180 ARA 86S 7B 180M4 ARA 86S IAK180
157	188	*313	1128	1,90	188	940	2,25	9,20	13,1	19,3	0815/38060			
186	223	*371	952	2,10	223	794	2,50	7,77	12,6	18,6	0815/42056			
219	263	*438	808	2,30	263	673	2,75	6,58	12,2	17,9	0815/46052			



4

P_N = 22 kW / 30 HP

50 - 60 - 100 Hz 22 - 26 - 44 kW					60 Hz 22 kW			bei/at 50 Hz (F _a =0) (F _r =0)				m kg		ZT Code
n ₅₀ min ⁻¹	n ₆₀ min ⁻¹	n ₁₀₀ min ⁻¹	M ₂ Nm	f _B	n ₆₀ min ⁻¹	M ₂ Nm	f _B	i	F _{rN} kN	F _{aN} kN				
					11	18626	0,80	155,12	**	133,7	FSA 137A 7B 180L4 FSA 137A IAK180 FRA 137A 7B 180L4 FRA 137A IAK180	643 474 791 622	264 546 486 546	1317/13125
					13	16675	0,85	138,74	**	134,3				1325/10086
12	14	23	17957	0,80	14	14964	0,95	124,66	**	134,3				1325/11085
13	16	26	16287	0,90	16	13572	1,05	112,93	36,7	134,0				1325/12084
16	19	31	13555	1,05	19	11296	1,25	94,49	71,7	132,5				1325/14082
18	22	36	11608	1,25	22	9673	1,45	80,66	86,1	130,5				1325/16080
21	25	42	10053	1,40	25	8377	1,70	69,91	91,7	128,3				1325/18078
24	29	48	8828	1,60	29	7356	1,95	61,30	90,1	126,0				1325/20076
27	32	54	7810	1,80	32	6509	2,20	54,26	88,5	123,6				1325/22074
30	36	60	6957	2,05	36	5797	2,45	48,40	86,9	121,2				1325/24072
34	40	67	6253	2,25	40	5211	2,70	43,43	85,3	118,8	1325/26070			
37	45	75	5633	2,50	45	4694	3,00	39,18	83,6	116,5	FSA 131A 7B 180L4 FSA 131A IAK180 FRA 131A 7B 180L4 FRA 131A IAK180	467 298 547 378	264 546 486 546	1325/28068
43	52	86	4863	2,90	52	4053	3,50	33,83	81,2	113,1				1325/31065
19	23	38	10943	0,75	23	9119	0,90	76,05	**	36,4				1317/13125
22	26	43	9772	0,85	26	8143	1,00	68,02	**	36,9				1325/10086
24	29	48	8791	0,95	29	7326	1,10	61,12	23,4	37,2				1325/11085
26	32	53	7958	1,05	32	6632	1,25	55,36	23,8	37,3				1325/12084
32	38	63	6670	1,20	38	5558	1,45	46,33	24,1	37,3				1325/14082
37	44	74	5694	1,45	44	4745	1,70	39,55	24,1	36,9				1325/16080
43	51	85	4932	1,65	51	4110	1,95	34,27	24,0	36,4				1325/18078
49	58	97	4323	1,90	58	3603	2,25	30,06	23,7	35,8				1325/20076
55	66	110	3827	2,10	66	3189	2,55	26,60	23,4	35,2	1325/22074			
62	74	123	3416	2,35	74	2847	2,85	23,73	23,0	34,6	1325/24072			
69	82	137	3063	2,65	82	2552	3,15	21,29	22,6	33,9	1325/26070			
76	91	152	2764	2,90	91	2304	3,50	19,21	22,2	33,2	1325/28068			
80	96	159	2639	2,60	96	2200	3,10	18,33	21,4	32,3	FSA 131S 7B 180L4 FSA 131S IAK180 FRA 131S 7B 180L4 FRA 131S IAK180	467 298 547 378	264 546 486 546	1325/16080
92	110	184	2286	3,00	110	1905	3,60	15,89	20,9	31,4				1325/18078
105	126	210	2005	3,40	126	1671	4,10	13,93	20,4	30,6				1325/20076
118	142	237	1774	3,85	142	1479	4,60	12,33	19,9	29,8				1325/22074
133	159	266	1583	4,20	159	1319	5,05	11,00	19,4	29,0				1325/24072
148	178	296	1421	4,55	178	1184	5,45	9,87	18,9	28,2				1325/26070
164	197	328	1281	4,55	197	1068	5,45	8,91	18,5	27,5				1325/28068
190	228	380	1106	4,55	228	922	5,45	7,69	17,8	26,5				1325/31065
218	262	437	962	6,20	262	802	7,40	6,69	17,2	25,6				1325/34062
250	300	499	841	6,70	300	701	8,05	5,85	16,6	24,7				1325/37059
36	43	71	5885	0,85	32	6509	0,80	54,33	**	27,8	FSA 111A 7B 180L4 FSA 111A IAK180 FRA 111A 7B 180L4 FRA 111A IAK180	374 205 435 266	264 546 486 546	1125/11071
42	51	84	4990	1,05	36	5895	0,85	49,10	**	28,2				1125/12070
49	59	98	4305	1,20	43	4904	1,05	40,88	**	28,6				1125/14068
56	67	112	3752	1,35	51	4159	1,25	34,72	**	28,6				1125/16066
64	76	127	3303	1,55	59	3588	1,40	29,93	21,1	28,5				1125/18064
72	86	144	2926	1,75	67	3126	1,60	26,09	21,0	28,2				1125/20062
81	97	161	2610	1,95	76	2753	1,85	22,96	20,7	27,8				1125/22060
90	108	180	2337	2,15	86	2438	2,10	20,34	20,5	27,3				1125/24058
110	131	219	1919	2,35	97	2175	2,30	18,13	20,1	26,9				1125/26056
126	151	251	1673	2,65	108	1948	2,60	16,23	19,8	26,4				1125/28054
143	171	286	1471	2,95	131	1599	2,80	13,33	18,6	24,9	FSA 111S 7B 180L4 FSA 111S IAK180 FRA 111S 7B 180L4 FRA 111S IAK180	374 205 435 266	264 546 486 546	1125/18064
161	193	322	1304	3,20	151	1394	3,15	11,63	18,2	24,3				1125/20062
181	217	362	1162	3,55	171	1226	3,50	10,23	17,7	23,7				1125/22060
202	242	404	1041	3,80	193	1087	3,85	9,06	17,3	23,1				1125/24058
237	284	473	888	4,25	217	968	4,25	8,08	16,8	22,5				1125/26056
276	331	552	762	4,70	242	867	4,60	7,23	16,4	21,9				1125/28054
320	384	640	656	5,10	284	740	5,10	6,17	15,8	21,1				1125/31051
					331	635	5,60	5,29	15,2	20,3				1125/34048
					384	547	6,10	4,56	14,6	19,5				1125/37045

4

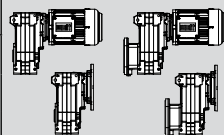
$P_N = 22 \text{ kW} / 30 \text{ HP}$

50 - 60 - 100 Hz 22 - 26 - 44 kW					60 Hz 22 kW			i	bei/at 50 Hz ($F_a=0$) ($F_r=0$)			m kg		ZT Code			
n_{50} min ⁻¹	n_{60} min ⁻¹	n_{100} min ⁻¹	M_2 Nm	f_B	n_{60} min ⁻¹	M_2 Nm	f_B		F_{rN} kN	F_{aN} kN							
					56	3733	0,80	31,13	**	19,7	ASA 86A 7B 180L4 ASA 86A IAK180 ARA 86A 7B 180L4 ARA 86A IAK180	284 115 314 145	262 546 486 546	0815/23075			
					66	3172	0,90	26,43	**	20,1				0815/26072			
64	77	*129	3267	0,90	77	2723	1,05	22,71	**	20,3				0815/29069			
74	89	*148	2832	1,00	89	2360	1,20	19,69	13,4	20,3				0815/32066			
85	102	*170	2472	1,15	102	2060	1,40	17,18	13,4	20,2				0815/35063			
97	116	*194	2168	1,30	116	1807	1,55	15,07	13,4	20,0				0815/38060			
115	138	*229	1832	1,55	138	1526	1,85	12,73	13,2	19,6				0815/42056			
135	162	*271	1553	1,85	162	1294	2,20	10,79	13,0	19,2				0815/46052			
139	167	*279	1508	1,45	167	1257	1,75	10,48	12,7	18,9				ASA 86S 7B 180L4 ASA 86S IAK180 ARA 86S 7B 180L4 ARA 86S IAK180	284 115 314 145	262 546 486 546	0815/35063
159	191	*318	1323	1,60	191	1103	1,90	9,20	12,5	18,5							0815/38060
188	226	*376	1118	1,80	226	931	2,15	7,77	12,1	17,9	0815/42056						
222	266	*444	947	1,95	266	789	2,35	6,58	11,8	17,3	0815/46052						

4



$P_N = 30 \text{ kW} / 40 \text{ HP}$

50 - 60 - 100 Hz 30 - 36 - 60 kW					60 Hz 30 kW			i	bei/at 50 Hz ($F_a=0$) ($F_r=0$)			m kg		ZT Code
n_{50} min ⁻¹	n_{60} min ⁻¹	n_{100} min ⁻¹	M_2 Nm	f_B	n_{60} min ⁻¹	M_2 Nm	f_B		F_{rN} kN	F_{aN} kN				
					16	18508	0,80	112,93	**	115,8	FSA 137A 7B 200L4 FSA 137A IA200 FRA 137A 7B 200L4 FRA 137A IA200	704 489 852 637	264 546 486 546	1325/12084
16	19	31	18484	0,80	19	15403	0,95	94,49	**	117,4				1325/14082
18	22	36	15829	0,90	22	13191	1,10	80,66	45,1	117,6				1325/16080
21	25	42	13708	1,05	25	11423	1,25	69,91	70,3	117,1				1325/18078
24	29	48	12038	1,20	29	10032	1,40	61,30	82,5	116,1				1325/20076
27	32	54	10651	1,35	32	8875	1,60	54,26	81,8	114,9				1325/22074
30	36	60	9487	1,50	36	7906	1,80	48,40	80,9	113,4				1325/24072
34	40	67	8527	1,65	40	7106	2,00	43,43	79,9	111,9				1325/26070
37	45	75	7681	1,85	45	6401	2,20	39,18	78,9	110,2				1325/28068
43	52	86	6632	2,15	52	5527	2,55	33,83	77,1	107,6				1325/31065
50	60	99	5776	2,45	60	4814	2,95	29,42	75,4	105,1	1325/34062			
57	68	114	5044	2,80	68	4203	3,35	25,72	73,5	102,4	1325/37059			
65	78	129	4435	3,20	78	3696	3,80	22,59	71,7	99,8	1325/40056			
					29	9990	0,85	61,12	**	29,3	FSA 131A 7B 200L4 FSA 131A IA200 FRA 131A 7B 200L4 FRA 131A IA200	528 313 608 393	264 546 486 546	1325/11085
					32	9044	0,90	55,36	**	30,2				1325/12084
32	38	63	9095	0,90	38	7579	1,10	46,33	19,0	31,3				1325/14082
37	44	74	7764	1,05	44	6470	1,25	39,55	19,9	31,8				1325/16080
43	51	85	6725	1,20	51	5604	1,45	34,27	20,4	32,0				1325/18078
49	58	97	5895	1,40	58	4913	1,65	30,06	20,6	31,9				1325/20076
55	66	110	5219	1,55	66	4349	1,85	26,60	20,7	31,8				1325/22074
62	74	123	4659	1,75	74	3882	2,10	23,73	20,6	31,5				1325/24072
69	82	137	4176	1,95	82	3480	2,30	21,29	20,5	31,1				1325/26070
76	91	152	3770	2,15	91	3141	2,55	19,21	20,3	30,8				1325/28068
88	106	176	3256	2,50	106	2713	2,95	16,58	20,0	30,1	1325/31065			
92	110	184	3118	2,20	110	2598	2,65	15,89	19,2	29,2	FSA 131S 7B 200L4 FSA 131S IA200 FRA 131S 7B 200L4 FRA 131S IA200	528 313 608 393	264 546 486 546	1325/18078
105	126	210	2734	2,50	126	2278	3,00	13,93	18,9	28,6				1325/20076
118	142	237	2420	2,80	142	2016	3,35	12,33	18,6	28,0				1325/22074
133	159	266	2159	3,10	159	1799	3,70	11,00	18,2	27,4				1325/24072
148	178	296	1937	3,35	178	1614	4,00	9,87	17,9	26,9				1325/26070
164	197	328	1747	3,35	197	1456	4,00	8,91	17,5	26,3				1325/28068
190	228	380	1509	3,35	228	1257	4,00	7,69	17,0	25,4				1325/31065
218	262	437	1312	4,55	262	1093	5,45	6,69	16,5	24,6				1325/34062
250	300	499	1147	4,95	300	956	5,90	5,85	16,0	23,8				1325/37059
284	341	569	1007	5,30	341	839	6,35	5,13	15,5	23,1				1325/40056
337	404	674	850	5,80	404	709	7,00	4,33	14,8	22,1	1325/44052			
					51	5671	0,90	34,72	**	23,7	FSA 111A 7B 200L4 FSA 111A IA200 FRA 111A 7B 200L4 FRA 111A IA200	435 220 496 281	264 546 486 546	1125/16066
49	59	*98	5871	0,90	59	4892	1,05	29,93	**	24,2				1125/18064
56	67	*112	5116	1,00	67	4263	1,20	26,09	**	24,5				1125/20062
64	76	*127	4505	1,15	76	3754	1,35	22,96	18,0	24,5				1125/22060
72	86	*144	3990	1,30	86	3325	1,55	20,34	18,1	24,5				1125/24058
81	97	*161	3559	1,45	97	2966	1,70	18,13	18,0	24,3				1125/26056
90	108	*180	3187	1,60	108	2656	1,90	16,23	17,9	24,1				1125/28054
94	113	*189	3035	1,50	113	2529	1,80	15,47	17,1	23,2				1125/16066
110	131	*219	2616	1,70	131	2180	2,05	13,33	16,9	22,9				1125/18064
126	151	*251	2281	1,95	151	1901	2,30	11,63	16,7	22,5				1125/20062
143	171	*286	2006	2,15	171	1672	2,60	10,23	16,4	22,1	1125/22060			
161	193	*322	1778	2,35	193	1482	2,85	9,06	16,1	21,7	1125/24058			
181	217	*362	1585	2,60	217	1321	3,10	8,08	15,8	21,2	1125/26056			
202	242	*404	1419	2,80	242	1183	3,35	7,23	15,5	20,8	1125/28054			
237	284	*473	1210	3,15	284	1009	3,75	6,17	15,0	20,1	1125/31051			
276	331	*552	1039	3,45	331	866	4,10	5,29	14,5	19,4	1125/34048			
320	384	*640	895	3,75	384	746	4,45	4,56	14,1	18,8	1125/37045			
371	445	*742	773	4,00	445	644	4,80	3,94	13,6	18,1	1125/40042			

* P_t (Thermische Grenzleistung) siehe Seite 187.
* P_t (Thermal power limit) see page 187.

** ... auf Anfrage
** ... on request

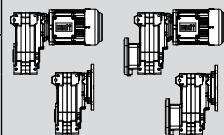
P_N = 37 kW / 50 HP



50 - 60 Hz 37 - 44 kW				60 Hz 37 kW			i	bei/at 50 Hz (F _a =0) (F _r =0)			m kg		ZT Code
n ₅₀ min ⁻¹	n ₆₀ min ⁻¹	M ₂ Nm	f _B	n ₆₀ min ⁻¹	M ₂ Nm	f _B		F _{rN} kN	F _{aN} kN				
				22	16179	0,90	80,66	**	106,3	FSA 137A 7B 225S4 FSA 137A IA225 FRA 137A 7B 225S4 FRA 137A IA225	771 489 919 637	264 546 486 546	1325/16080
21	25	16826	0,85	25	14022	1,00	69,91	22,7	107,3				1325/18078
24	29	14723	1,00	29	12269	1,15	61,30	60,0	107,5				1325/20076
27	33	13039	1,10	33	10866	1,30	54,26	75,8	107,2				1325/22074
30	36	11623	1,25	36	9686	1,45	48,40	75,6	106,6				1325/24072
34	41	10454	1,35	41	8712	1,65	43,43	75,2	105,7				1325/26070
38	45	9423	1,50	45	7852	1,80	39,18	74,6	104,6				1325/28068
44	52	8123	1,75	52	6769	2,10	33,83	73,4	102,8				1325/31065
50	60	7067	2,00	60	5889	2,40	29,42	72,1	100,8				1325/34062
57	69	6188	2,30	69	5157	2,75	25,72	70,7	98,7				1325/37059
65	78	5428	2,60	78	4523	3,10	22,59	69,2	96,5	1325/40056			
77	93	4583	3,10	93	3819	3,70	19,07	67,1	93,5	1325/44052			
				38	9289	0,90	46,33	**	26,1	FSA 131A 7B 225S4 FSA 131A IA225 FRA 131A 7B 225S4 FRA 131A IA225	595 313 675 393	264 546 486 546	1325/14082
37	45	9499	0,85	45	7916	1,05	39,55	16,0	27,4				1325/16080
43	52	8237	1,00	52	6864	1,20	34,27	17,1	28,1				1325/18078
49	59	7226	1,15	59	6022	1,35	30,06	17,8	28,6				1325/20076
55	66	6390	1,30	66	5325	1,55	26,60	18,2	28,8				1325/22074
62	74	5699	1,45	74	4749	1,70	23,73	18,5	28,8				1325/24072
69	83	5121	1,60	83	4268	1,90	21,29	18,6	28,7				1325/26070
77	92	4619	1,75	92	3849	2,10	19,21	18,6	28,6				1325/28068
89	106	3988	2,05	106	3323	2,45	16,58	18,5	28,2	1325/31065			
				111	3183	2,15	15,89	17,6	27,2	FSA 131S 7B 225S4 FSA 131S IA225 FRA 131S 7B 225S4 FRA 131S IA225	595 313 675 393	264 546 486 546	1325/18078
93	111	3820	1,80	111	3183	2,15	15,89	17,6	27,2				1325/20076
106	127	3349	2,05	127	2791	2,45	13,93	17,5	26,9				1325/22074
119	143	2964	2,30	143	2470	2,75	12,33	17,4	26,5				1325/24072
134	160	2645	2,55	160	2204	3,05	11,00	17,2	26,1				1325/26070
149	179	2373	2,75	179	1978	3,25	9,87	16,9	25,6				1325/28068
165	198	2140	2,75	198	1784	3,25	8,91	16,7	25,2				1325/31065
191	229	1848	2,75	229	1540	3,25	7,69	16,3	24,5				1325/34062
220	264	1607	3,70	264	1339	4,45	6,69	15,8	23,8				1325/37059
251	302	1406	4,05	302	1171	4,85	5,85	15,4	23,1				1325/40056
286	344	1234	4,35	344	1028	5,20	5,13	15,0	22,4	1325/44052			
339	407	1042	4,75	407	868	5,70	4,33	14,4	21,5				
				59	5997	0,85	29,93	**	20,6	FSA 111A 7B 225S4 FSA 111A IA225 FRA 111A 7B 225S4 FRA 111A IA225	502 220 563 281	264 546 486 546	1125/18064
56	68	6276	0,80	68	5230	1,00	26,09	**	21,3				1125/20062
64	77	5521	0,95	77	4601	1,10	22,96	**	21,7				1125/22060
72	87	4887	1,05	87	4073	1,25	20,34	**	22,0				1125/24058
81	97	4357	1,15	97	3631	1,40	18,13	16,1	22,1				1125/26056
91	109	3900	1,30	109	3250	1,55	16,23	16,2	22,1				1125/28054
				114	3100	1,45	15,47	15,3	21,1	FSA 111S 7B 225S4 FSA 111S IA225 FRA 111S 7B 225S4 FRA 111S IA225	502 220 563 281	264 546 486 546	1125/16066
95	114	3719	1,20	114	3100	1,45	15,47	15,3	21,1				1125/18064
110	132	3206	1,40	132	2672	1,70	13,33	15,4	21,1				1125/20062
127	152	2793	1,60	152	2328	1,90	11,63	15,4	20,9				1125/22060
144	173	2459	1,75	173	2049	2,10	10,23	15,3	20,7				1125/24058
162	195	2178	1,95	195	1815	2,30	9,06	15,1	20,4				1125/26056
182	218	1941	2,10	218	1618	2,55	8,08	14,9	20,1				1125/28054
203	244	1738	2,30	244	1448	2,75	7,23	14,7	19,8				1125/31051
238	286	1483	2,55	286	1236	3,05	6,17	14,4	19,2				1125/34048
278	333	1272	2,80	333	1060	3,35	5,29	14,0	18,7				1125/37045
322	387	1096	3,05	387	914	3,65	4,56	13,6	18,1				1125/40042
373	448	947	3,30	448	789	3,95	3,94	13,1	17,5				

$P_N = 45 \text{ kW} / 60 \text{ HP}$

50 - 60 Hz 45 - 54 kW				60 Hz 45 kW			i	bei/at 50 Hz ($F_a=0$) ($F_r=0$)			m kg		ZT Code
n_{50} min ⁻¹	n_{60} min ⁻¹	M_2 Nm	f_B	n_{60} min ⁻¹	M_2 Nm	f_B		F_{rN} kN	F_{aN} kN				
				25	16893	0,85	69,91	**	96,3	FSA 137A 7B 225M4 FSA 137A IA225 FRA 137A 7B 225M4 FRA 137A IA225	818 489 966 637	264 546 486 546	1325/18078
24	29	17832	0,80	29	14860	0,95	61,30	**	97,8				1325/20076
27	33	15742	0,90	33	13118	1,10	54,26	46,5	98,6				1325/22074
31	37	14044	1,00	37	11703	1,20	48,40	67,2	98,9				1325/24072
34	41	12603	1,15	41	10502	1,35	43,43	69,7	98,8				1325/26070
38	45	11369	1,25	45	9474	1,50	39,18	69,6	98,4				1325/28068
44	53	9812	1,45	53	8176	1,75	33,83	69,2	97,4				1325/31065
50	60	8544	1,65	60	7120	2,00	29,42	68,5	96,1				1325/34062
58	69	7474	1,90	69	6228	2,25	25,72	67,5	94,5				1325/37059
66	79	6561	2,15	79	5468	2,60	22,59	66,4	92,8				1325/40056
78	93	5538	2,55	93	4615	3,05	19,07	64,8	90,4	1325/44052			
				45	9576	0,85	39,55	**	22,4	FSA 131A 7B 225M4 FSA 131A IA225 FRA 131A 7B 225M4 FRA 131A IA225	642 313 722 393	264 546 486 546	1325/16080
43	52	9948	0,85	52	8290	1,00	34,27	**	23,8				1325/18078
49	59	8735	0,95	59	7279	1,10	30,06	14,4	24,8				1325/20076
56	67	7729	1,05	67	6441	1,25	26,60	15,3	25,4				1325/22074
62	75	6887	1,20	75	5739	1,40	23,73	15,9	25,8				1325/24072
70	83	6183	1,30	83	5153	1,60	21,29	16,3	26,0				1325/26070
77	93	5574	1,45	93	4645	1,75	19,21	16,6	26,1				1325/28068
89	107	4818	1,70	107	4015	2,00	16,58	16,8	26,1				1325/31065
93	112	4616	1,50	112	3847	1,80	15,89	15,8	25,0				1325/18078
106	128	4047	1,70	128	3372	2,05	13,93	15,9	24,9				1325/20076
120	144	3581	1,90	144	2984	2,30	12,33	16,0	24,7	1325/22074			
135	162	3195	2,10	162	2663	2,50	11,00	15,9	24,5	1325/24072			
150	180	2867	2,25	180	2389	2,70	9,87	15,8	24,2	1325/26070			
166	199	2586	2,25	199	2155	2,70	8,91	15,7	23,9	1325/28068			
193	231	2232	2,25	231	1860	2,70	7,69	15,4	23,4	1325/31065			
221	266	1942	3,05	266	1618	3,70	6,69	15,1	22,8	1325/34062			
253	304	1698	3,35	304	1415	4,00	5,85	14,8	22,2	1325/37059			
288	346	1491	3,60	346	1242	4,30	5,13	14,4	21,7	1325/40056			
342	410	1258	3,95	410	1049	4,75	4,33	13,9	20,9	1325/44052			
				68	6316	0,80	26,09	**	17,7	FSA 111A 7B 225M4 FSA 111A IA225 FRA 111A 7B 225M4 FRA 111A IA225	549 220 610 281	264 546 486 546	1125/20062
65	77	6663	0,80	77	5552	0,95	22,96	**	18,5				1125/22060
73	87	5903	0,85	87	4919	1,05	20,34	**	19,1				1125/24058
82	98	5267	0,95	98	4389	1,15	18,13	**	19,6				1125/26056
91	109	4712	1,10	109	3927	1,30	16,23	11,0	19,8				1125/28054
96	115	4491	1,00	115	3742	1,20	15,47	13,1	18,7	1125/16066			
111	133	3872	1,15	133	3226	1,40	13,33	13,6	19,0	1125/18064			
127	153	3376	1,30	153	2813	1,60	11,63	13,8	19,1	1125/20062			
145	174	2970	1,45	174	2475	1,75	10,23	13,9	19,1	1125/22060			
163	196	2632	1,60	196	2193	1,90	9,06	14,0	19,0	1125/24058			
183	220	2346	1,75	220	1955	2,10	8,08	13,9	18,9	1125/26056			
205	246	2100	1,90	246	1750	2,30	7,23	13,8	18,6	1125/28054			
240	288	1791	2,15	288	1493	2,55	6,17	13,6	18,3	1125/31051			
280	336	1537	2,35	336	1281	2,80	5,29	13,3	17,9	1125/34048			
325	389	1324	2,55	389	1104	3,05	4,56	13,0	17,4	1125/37045			
376	451	1143	2,70	451	953	3,25	3,94	12,6	16,9	1125/40042			

4

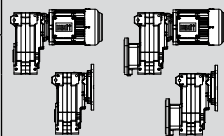
P_N = 55 kW / 75 HP

50 - 60 Hz 55 - 75 kW				60 Hz 55 kW			i	bei/at 50 Hz (F _a =0) (F _r =0)			m kg		ZT Code
n ₅₀ min ⁻¹	n ₆₀ min ⁻¹	M ₂ Nm	f _B	n ₆₀ min ⁻¹	M ₂ Nm	f _B		F _{rN} kN	F _{aN} kN				
				29	18162	0,80	61,30	**	85,7	FSA 137A 7B 250M4 - FRA 137A 7B 250M4 -	896 - 1044 -	264 - 486 -	1325/20076
				33	16033	0,90	54,26	**	87,9				1325/22074
31	*37	17165	0,85	37	14304	1,00	48,40	**	89,3				1325/24072
34	*41	15403	0,95	41	12836	1,10	43,43	51,5	90,2				1325/26070
38	*45	13896	1,05	45	11580	1,25	39,18	63,4	90,6				1325/28068
44	*53	11992	1,20	53	9993	1,45	33,83	63,9	90,7				1325/31065
50	*60	10442	1,35	60	8702	1,65	29,42	63,9	90,3				1325/34062
58	*69	9135	1,55	69	7612	1,85	25,72	63,6	89,4				1325/37059
66	*79	8019	1,75	79	6683	2,10	22,59	63,0	88,4				1325/40056
78	*93	6769	2,10	93	5641	2,50	19,07	61,9	86,6				1325/44052
				52	10132	0,80	34,27	**	18,4	FSA 131A 7B 250M4 - FRA 131A 7B 250M4 -	720 - 800 -	264 - 486 -	1325/18078
				59	8897	0,90	30,06	**	20,0				1325/20076
56	*67	9447	0,85	67	7872	1,05	26,60	11,4	21,1				1325/22074
62	*75	8417	1,00	75	7015	1,15	23,73	12,5	22,0				1325/24072
70	*83	7558	1,10	83	6298	1,30	21,29	13,4	22,6				1325/26070
77	*93	6813	1,20	93	5677	1,45	19,21	14,0	23,1				1325/28068
89	*107	5888	1,40	107	4907	1,65	16,58	14,6	23,4				1325/31065
93	*112	5642	1,25	112	4701	1,50	15,89	13,4	22,2				1325/18078
106	*128	4946	1,40	128	4122	1,70	13,93	13,9	22,5	1325/20076			
120	*144	4377	1,55	144	3648	1,85	12,33	14,2	22,6	1325/22074			
135	*162	3905	1,70	162	3254	2,05	11,00	14,4	22,6	1325/24072			
150	*180	3504	1,85	180	2920	2,20	9,87	14,4	22,5	1325/26070			
166	*199	3160	1,85	199	2634	2,20	8,91	14,5	22,3	1325/28068			
193	*231	2729	1,85	231	2274	2,20	7,69	14,4	22,0	1325/31065			
221	*266	2373	2,50	266	1978	3,00	6,69	14,2	21,6	1325/34062			
253	*304	2075	2,75	304	1729	3,30	5,85	14,0	21,2	1325/37059			
288	*346	1822	2,95	346	1518	3,55	5,13	13,7	20,8	1325/40056			
342	*410	1538	3,25	410	1282	3,85	4,33	13,4	20,1	1325/44052			